

GK-02



额定功率 / Motor power : 400W
电池配置 / Battery capacity : 18V=6Ah
充电时间 / Charging time : 2-3h
安装时间 / Time to bulid : 6-20 hours
最大载重 / Max weight : 50kg
产品净重 / Net weight : 30kg
续航时间 / Using time : 1hour

DOCYKE

GO-KART KIT
卡丁车套件

DOCYKE

目 录 CONTENTS

1	目 录 Contents
2-4	注意事项 Warning
5-30	安装步骤 Assembly drawing
41-43	快速安装图 Diagram

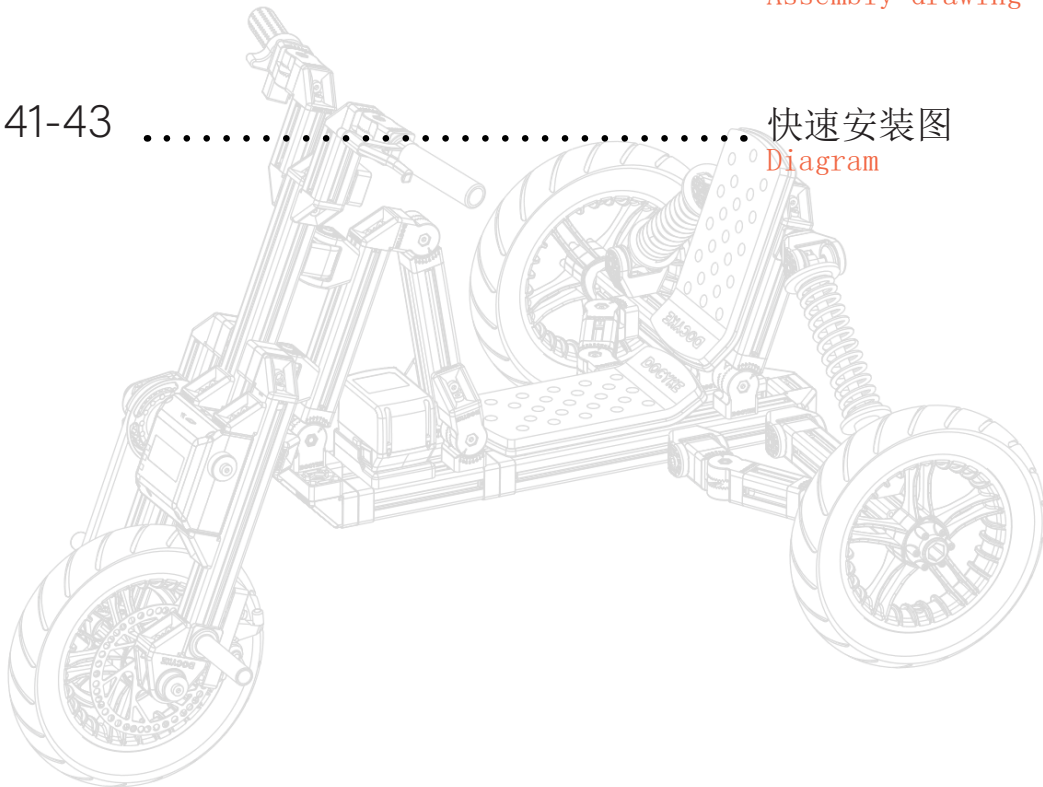

DOCYKE

在您构建玩具前请先阅读下列内容，以保证儿童的安全并防止玩具损坏，
更多说明请到官方站点进行下载：www.docyke.com

Please read instruction manual and warnings before installation.
More specification please check our website: www.docyke.com



警告说明! WARNING!

请在成人指导下安装使用。
Please assemble and use
under adult instruction.



警告说明:

多可的装配和使用需由成人陪同,并且成人需悉知所有警告条款和安装注意事项。

DOCYKE 的所有正规渠道销售的零部件都通过严格测试的合格产品,由于不遵照条款带来的人员受伤或产品损坏,我们将不承担任何责任。

WARNING:

DOCYKE should be assembled and used under adult supervision. Parents should review all the following warning and instructions in advance, and make sure that all riders understand all warnings, cautions, instructions and safety topics, and assure that young riders are able to safely and responsibly use this product. We recommends that you review and reinforce the information in this manual periodically with younger riders, and inspect and maintain your DOCYKE rides to insure their safety.

The rides and all the parts have been tested by official independent testing agencies. We shall not be responsible or liable, directly or indirectly, in any way for any personal injury or product damage caused by non-compliance with the terms and conditions in our manuals.

多可 使用规范:

DOCYKE use specification

1) 多可 由多个零件组装而成, 在使用过程中会造成零件松动, 请及时检查并紧固好零件。
Check frequently to make sure all parts are still firmly tightened and functioned properly.

2) 多可 所有零件都为官方测试的合格零件, 但如果不按操作说明, 超过零件的装配力矩 (25NM) 或产品的承重载荷会损坏零件。

Never exceed the maximum weight and assembly force(25nm). You can find the maximum weight for every specific ride in our manual.

3) 应尽量避免暴露在阳光, 水, 沙堆, 泥土等会造成其老化和缩短使用寿命的环境因素。
Avoid streets and Excessive exposure to sunlight ,water, sand, gravel, and other debris that will shorten the life of the docyke .

4) 应避免接近尖锐的物体, 以免刮伤其表面, 同时尽量在平缓的地区使用。
Avoid sharp bumps, drainage grates and sudden surface changes. Ride on smooth, paved surfaces.

5) 多可 由很多小零件组成, 部分表面尖锐, 请妥善保管并放置于儿童无法接触到的地方, 以免被幼儿误食或弄伤。

Before assembly, present a choking hazard to children under the age of three. Care should be taken during unpacking and assembly to insure that all small parts and plastic bags are accounted for and kept out of the reach of children.

6) 多可 不用时请放置在干燥的地方妥善保管。
Dirt, leaves, and other debris can damage, shrink, expand or weaken docyke parts. Keep your ride in a dry environment.

7) 多可 除螺钉外其余都为特别设计的零件, 请不要和市场上类似零件混用。
Most of the docyke's components are specially designed, please do not mix with similar parts on the market.

8) 检查充气轮胎气压不能大于 1.8bar(1.8 kgf/cm²)
Check the air pressure in the tires to max 1.8bar.

10) 适当着装, 不要穿宽松衣物或饰品, 让衣服、头发远离运动部件, 避免卷入其中。
Dress appropriately. Do not wear loose clothing or jewelry. Keep your hair, clothing and gloves away from moving parts. Avoid caught in moving parts.

11) 佩戴好个人防护装置, 安全装置后使用 多可, 如防滑鞋、安全帽等。
Use personal protective equipment. Always wear protective equipment such as non-skid safety shoes, hard hat etc.

12) 在进行任何调节, 更换附件或储存 多可 之前必须使电池与产品脱开, 减少以外启动危险。

Disconnect the battery pack from the DOCYKE before making any adjustments, changing accessories, or storing DOCYKE.



电气安全警告:

Electrical safety warning

阅读所有警告及说明! 不遵照以下警告和说明会导致电击, 着火或严重伤害!

Read all safety warnings and all instructions. Failure to follow the warnings and instructions may result in electric shock, fire or serious injury.

1) 充电器仅中室内使用, 并使充电及使用环境的清洁, 干燥。不得暴露在潮湿, 粉尘环境中, 否则会增加电击危险。

The charger is only used indoors, Keep work area clean and well lit. Do not expose DOCYKE to rain or wet conditions.

2) 只能用多可制造商规定的充电器及电池进行充电。

Recharge only with the charger and battery pack which specifically designated by DOCYKE.

3) 当电池不用时, 将它远离其它金属物体, 以防电池短路引起火灾或燃烧。

Keep the battery away from other metal objects when it is not used, in case shorting the battery terminal together may cause burns or fire.

4) 严禁打开电池及充电器, 可能造成短路, 火灾或燃烧。保护电池免受高温 (如长时间日照), 火焰, 水和湿气的侵害。有爆炸危险。

Do not open the battery and charger. Danger of short-circuiting. Protect the battery against heat, e.g, against continuous intense sunlight, fire, water, and moisture. Danger of explosion.

建议使用工具

RECOMMENDED TOOLS

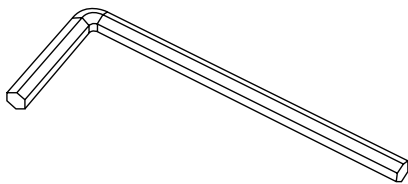

六角扳手 /Hex key

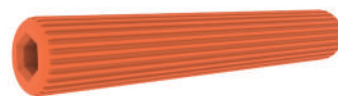

六角手柄 /Hex handle



钳子 /Tongs

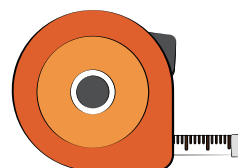

卷尺 /Tape

GK-02

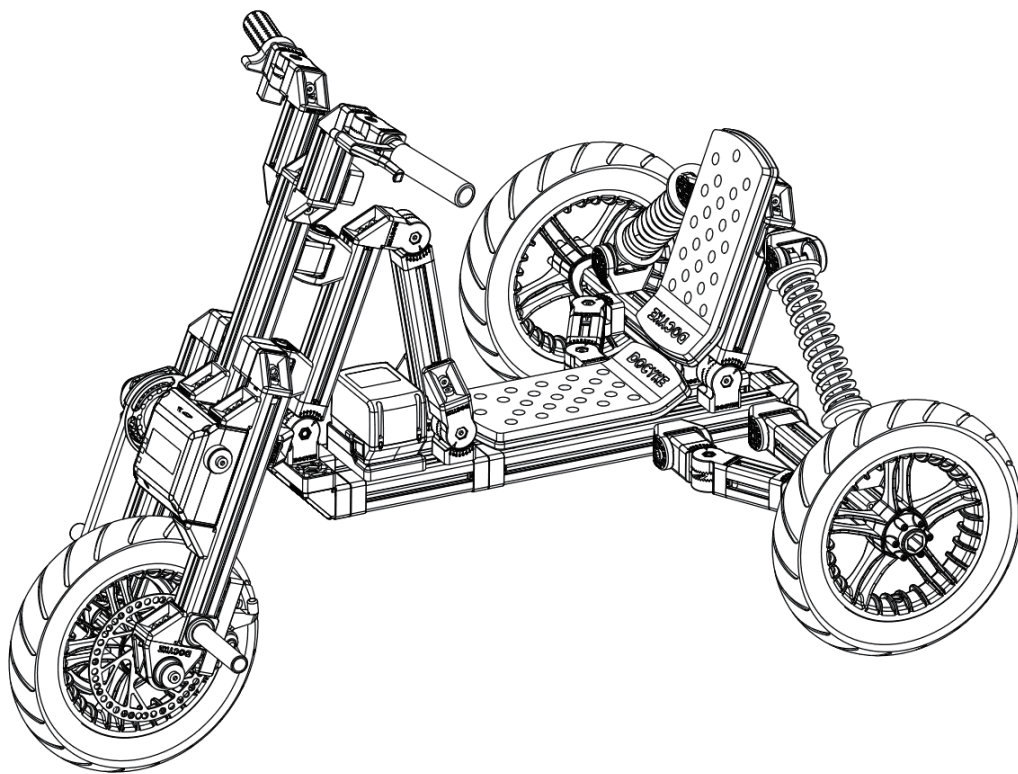

1 PART

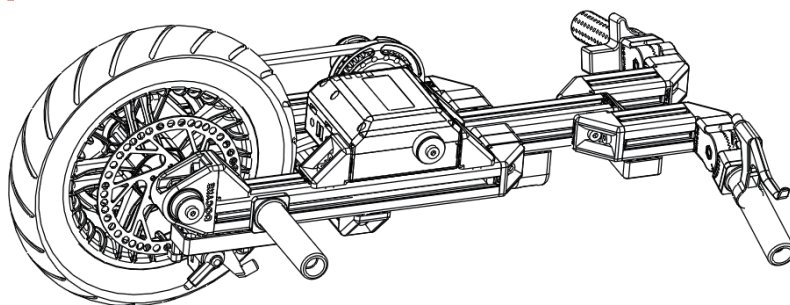

2 PART

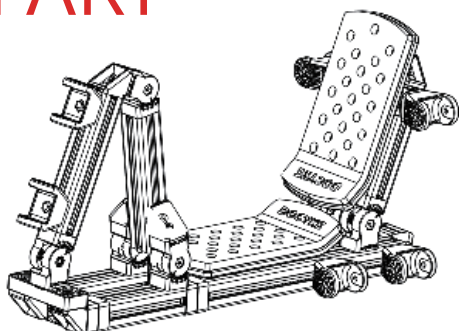

3 PART

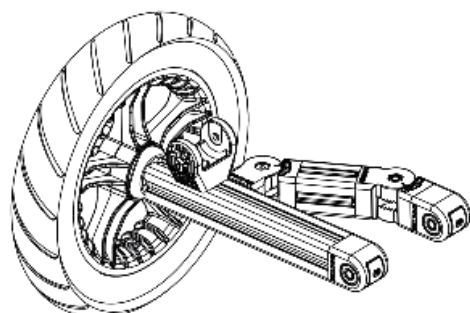

1 PART

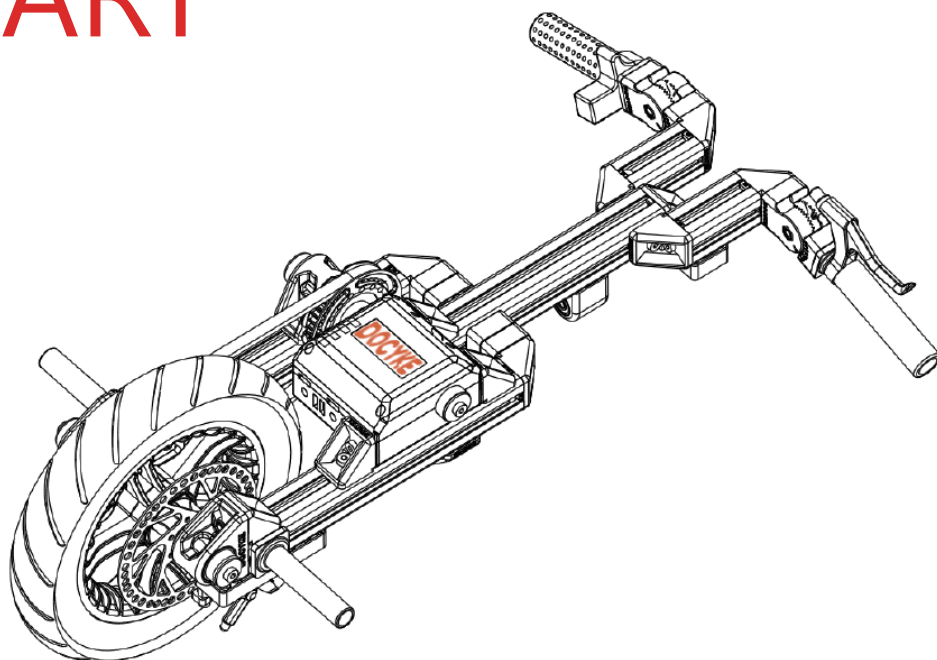

PART 1-1

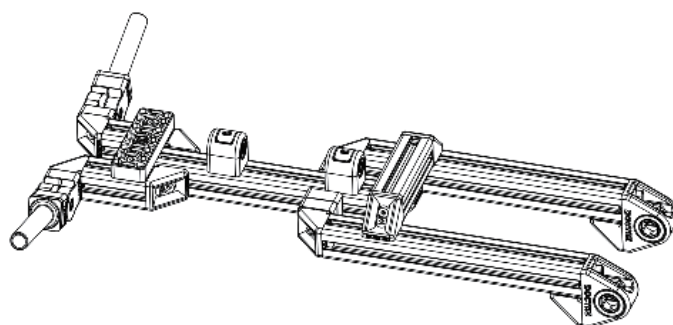

PART 1-2

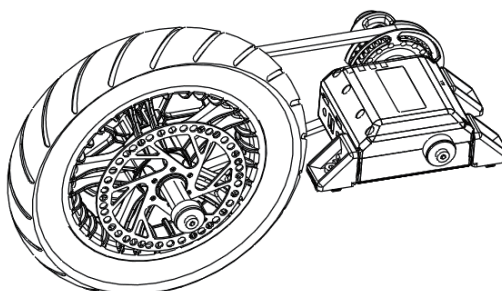

PART 1-1

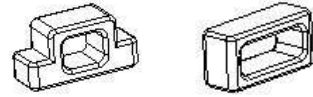
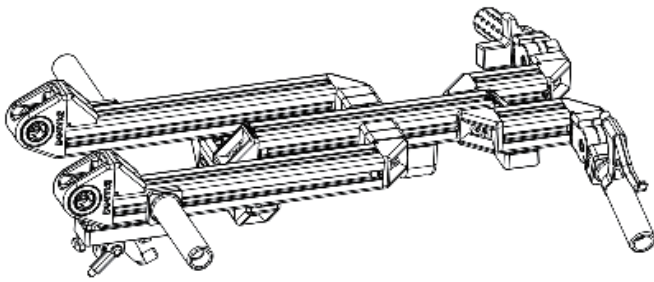

The positioning blocks are some of the smallest parts but they also some of the most important. Putting them in the right place is a key of the product.

产品中一共包含两种定位块，它是至关重要的部件，请仔细分辨。几乎所有零件的装配都会使用到他们，请务必按照说明使用，避免漏装或误装。

A

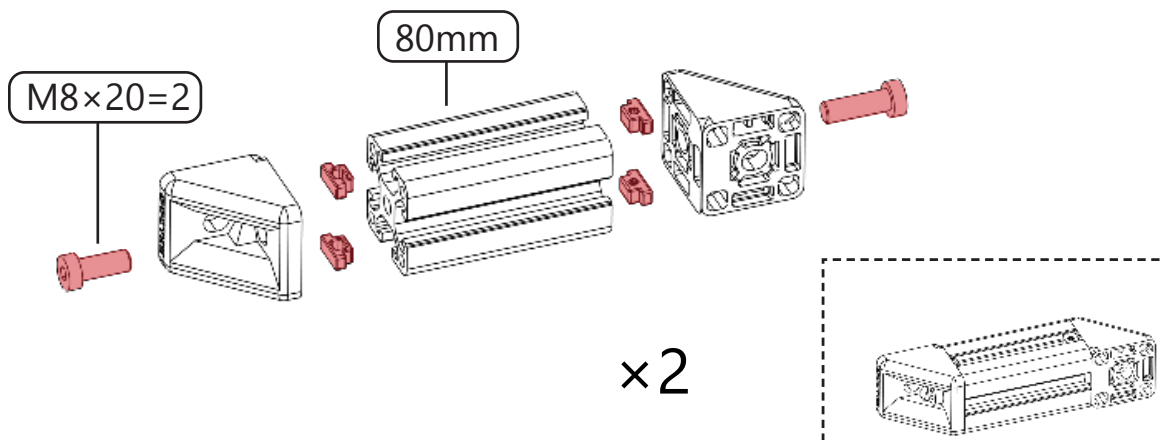

B

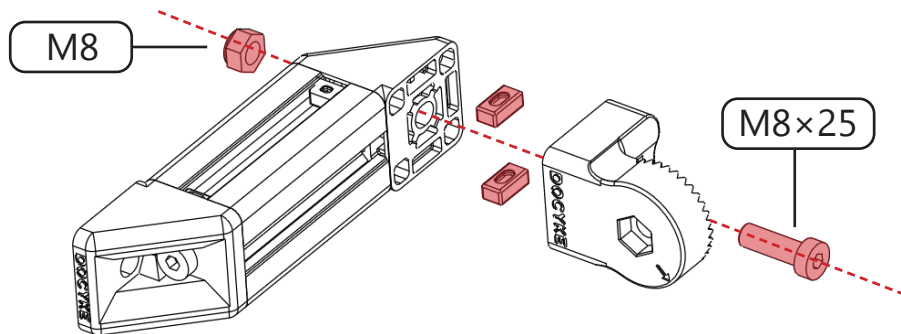

如图，对称组装共2个。
As shown in the figure, assemble 2 components.

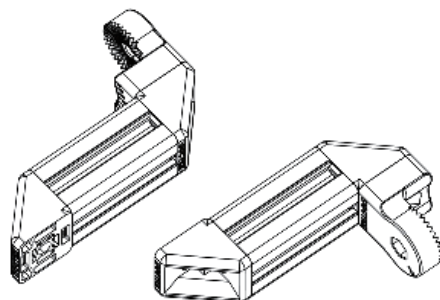

DOCYKE

C

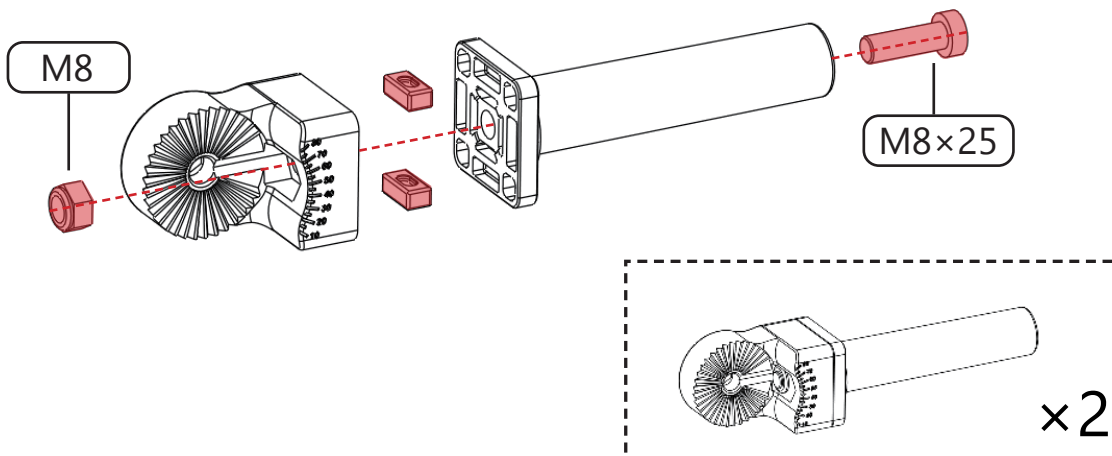

D

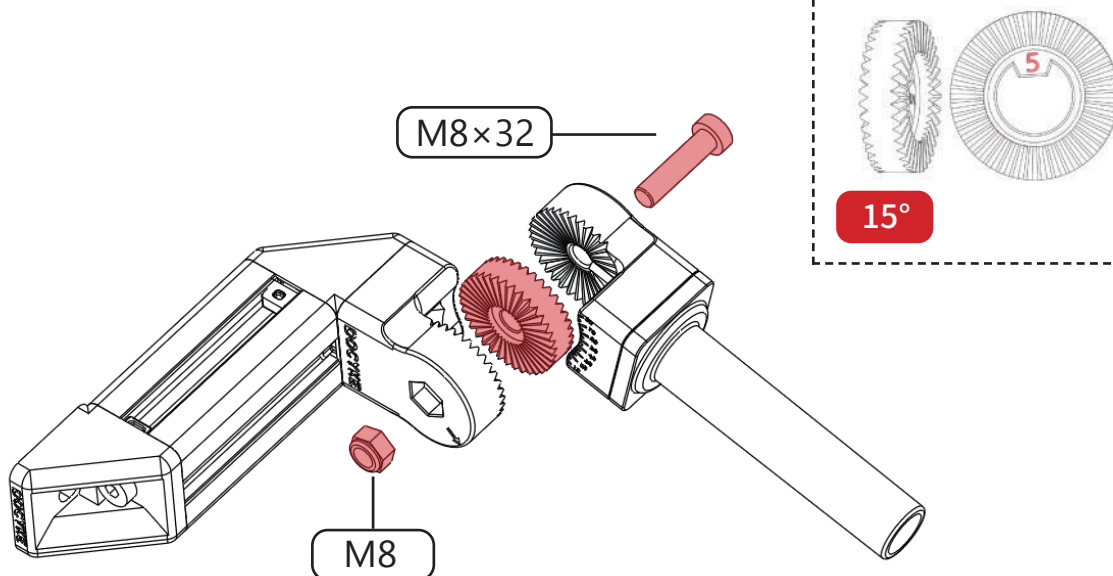

如图，对称组装共 2 个。
As shown in the figure,
assemble 2 components.



E

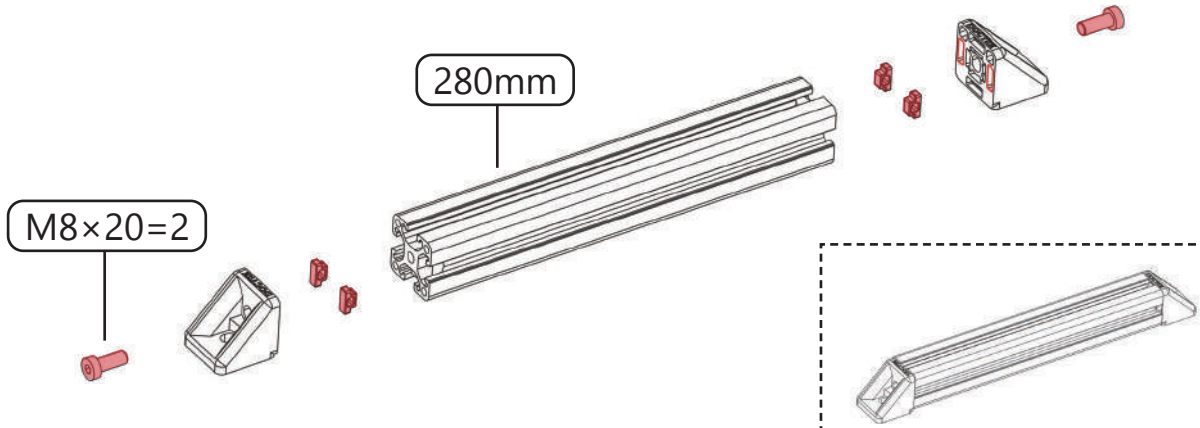

F

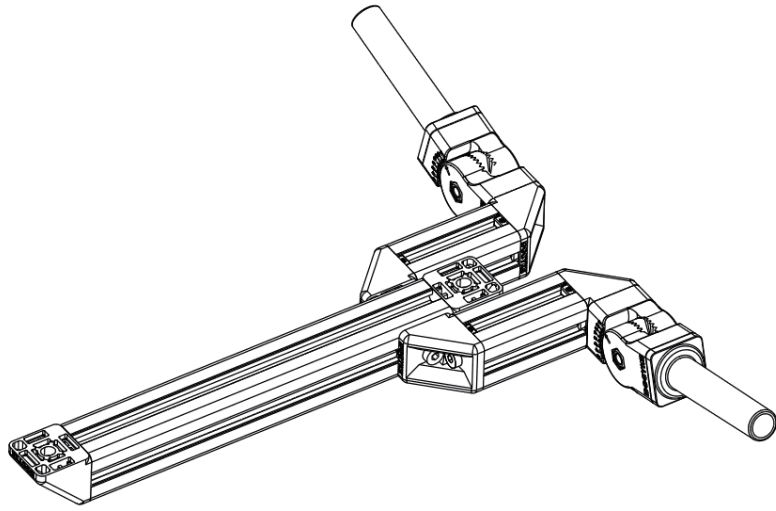
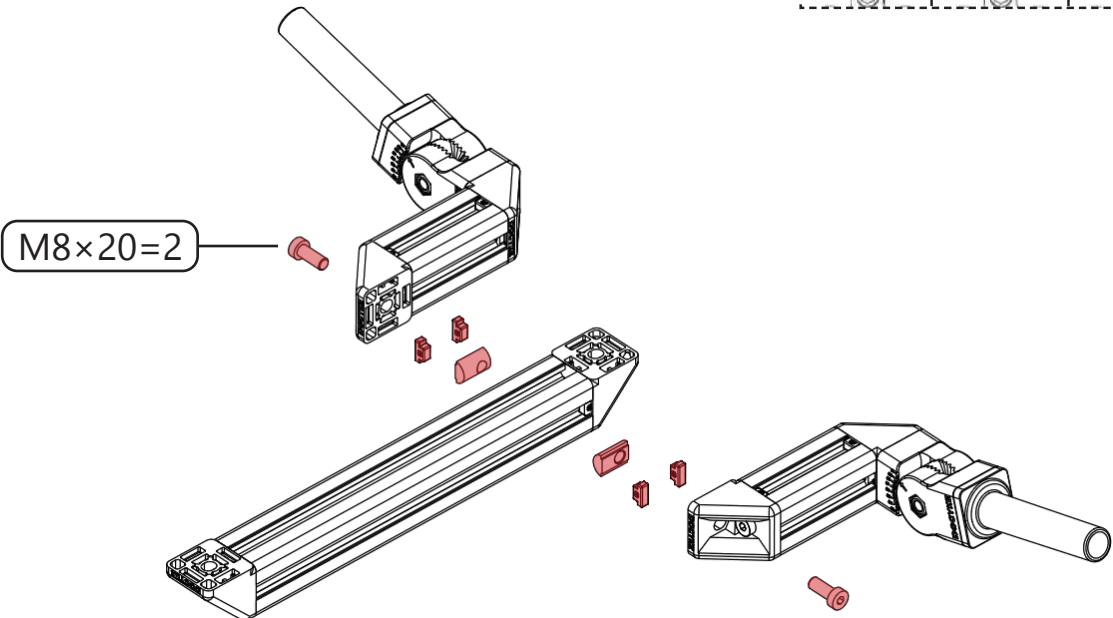

G

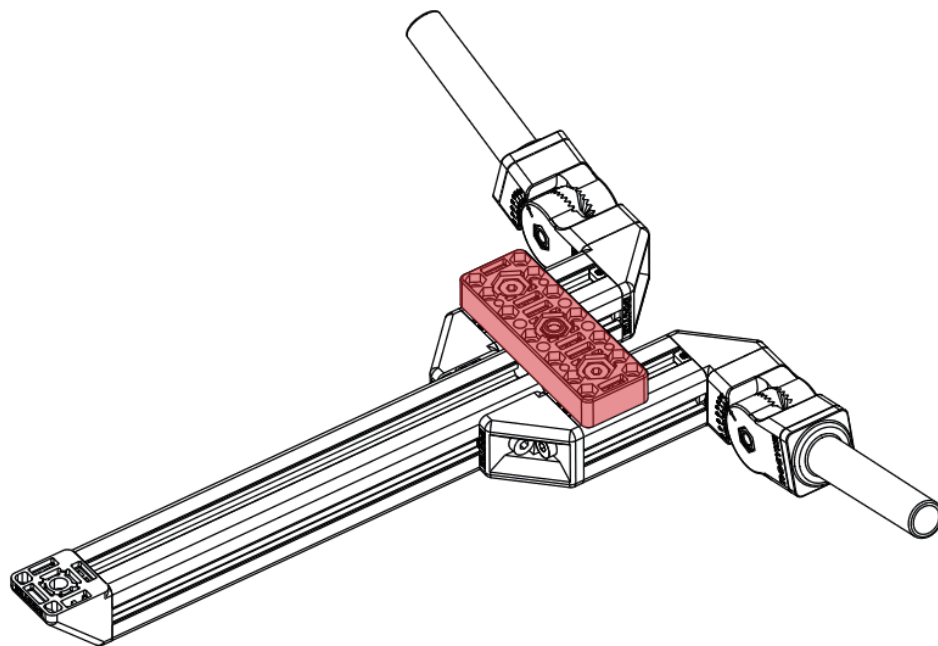
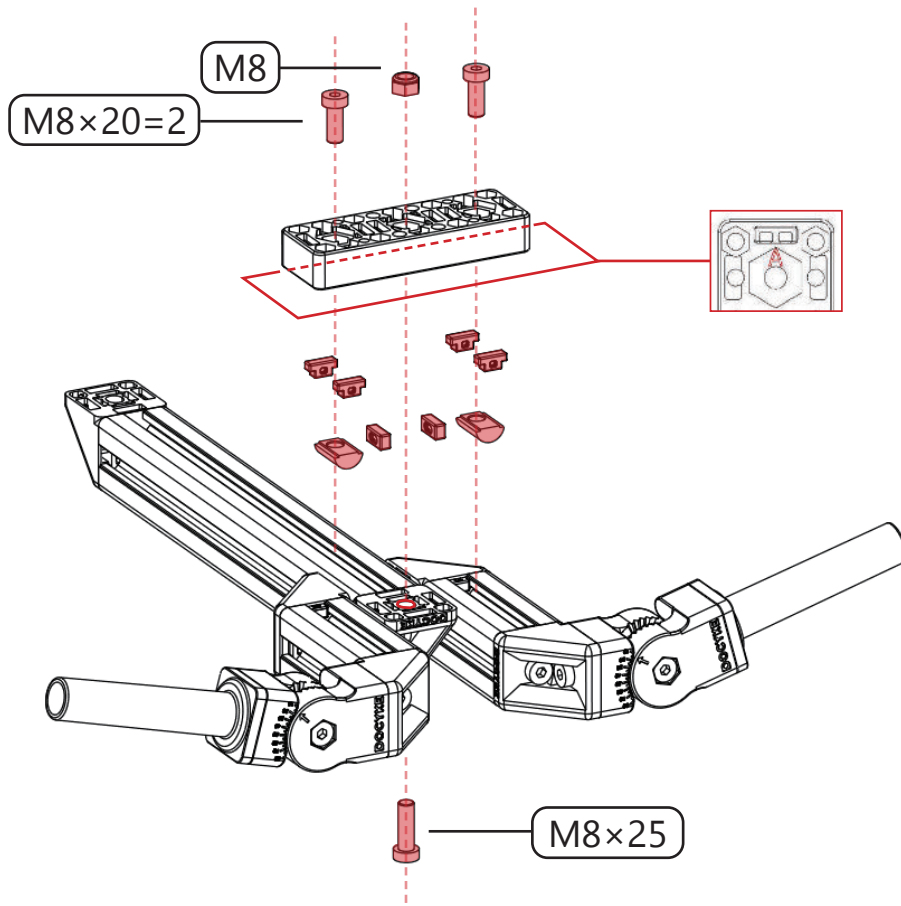

H

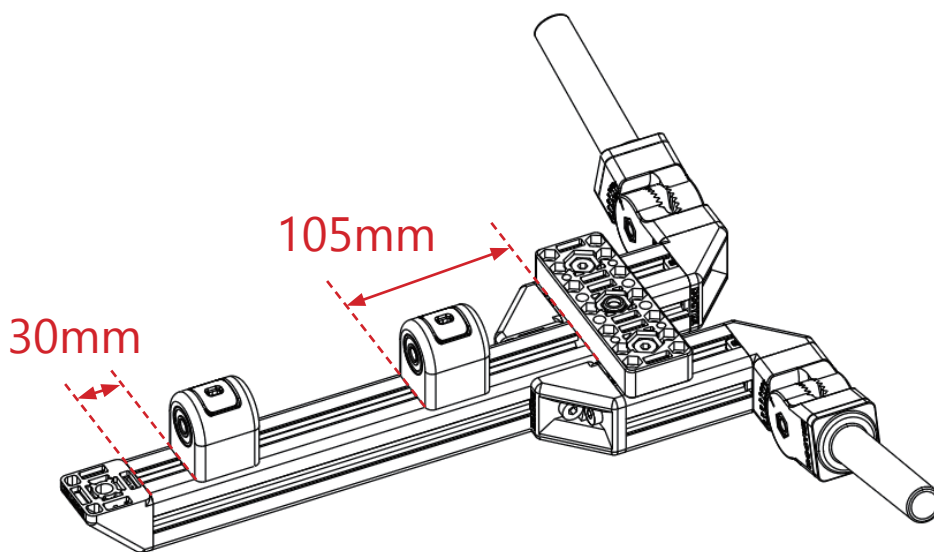
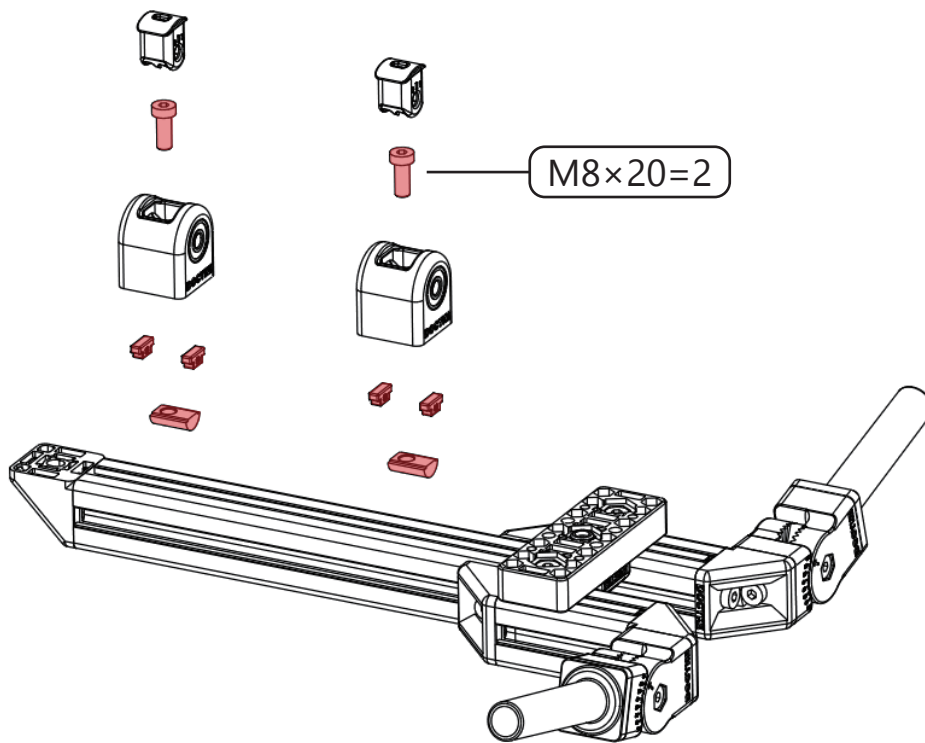

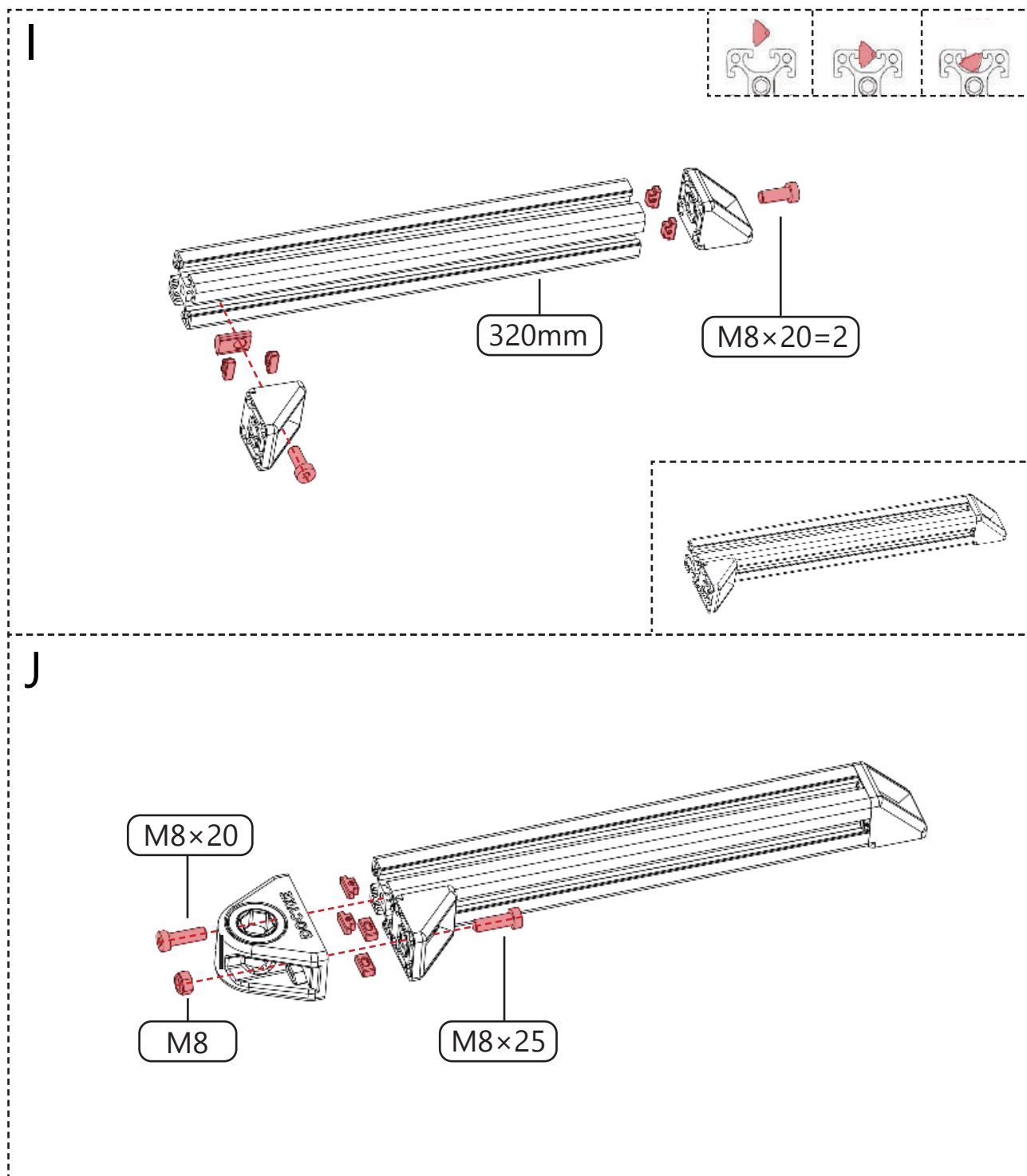

如图, 对称组装共 2 个。
As shown in the figure,
assemble 2 components.

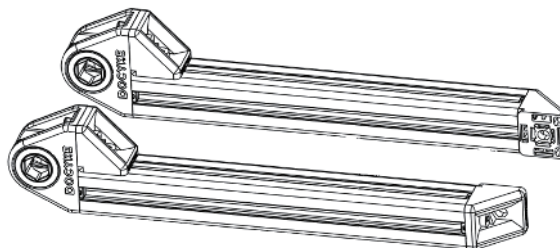

K

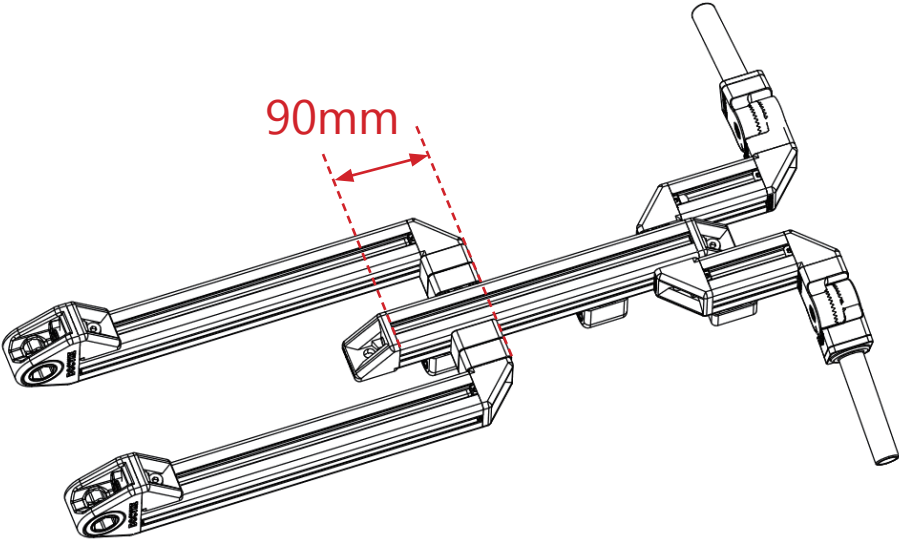
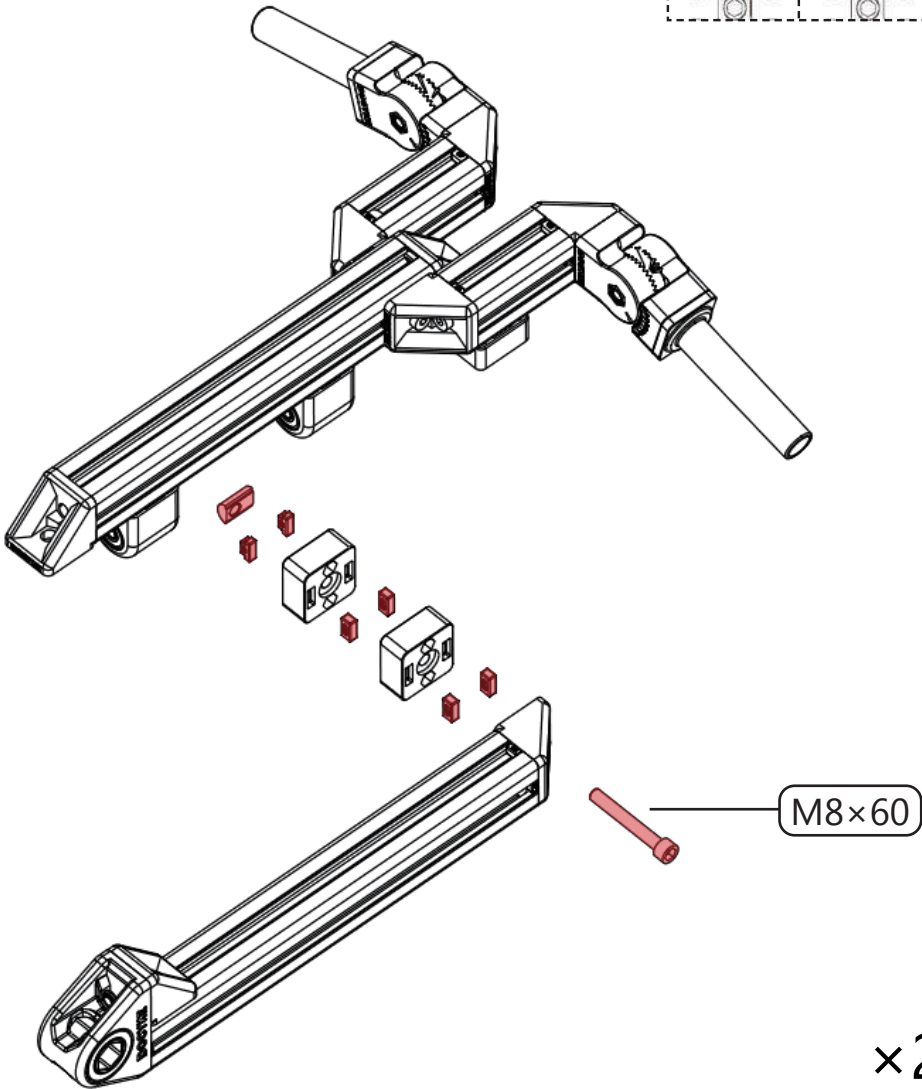

L

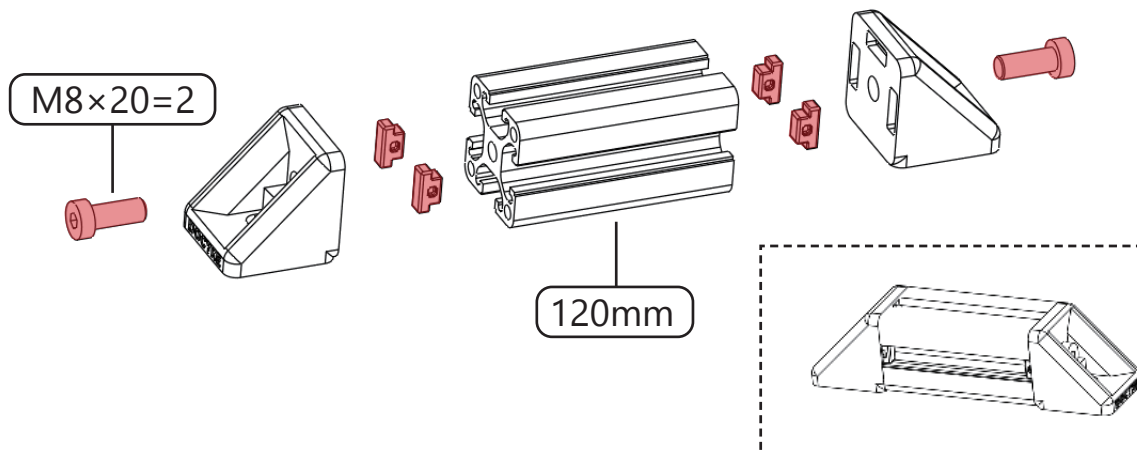

M

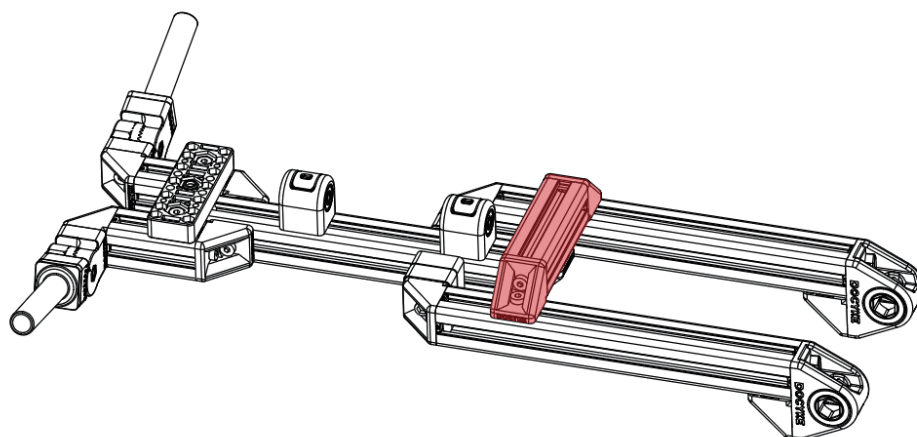
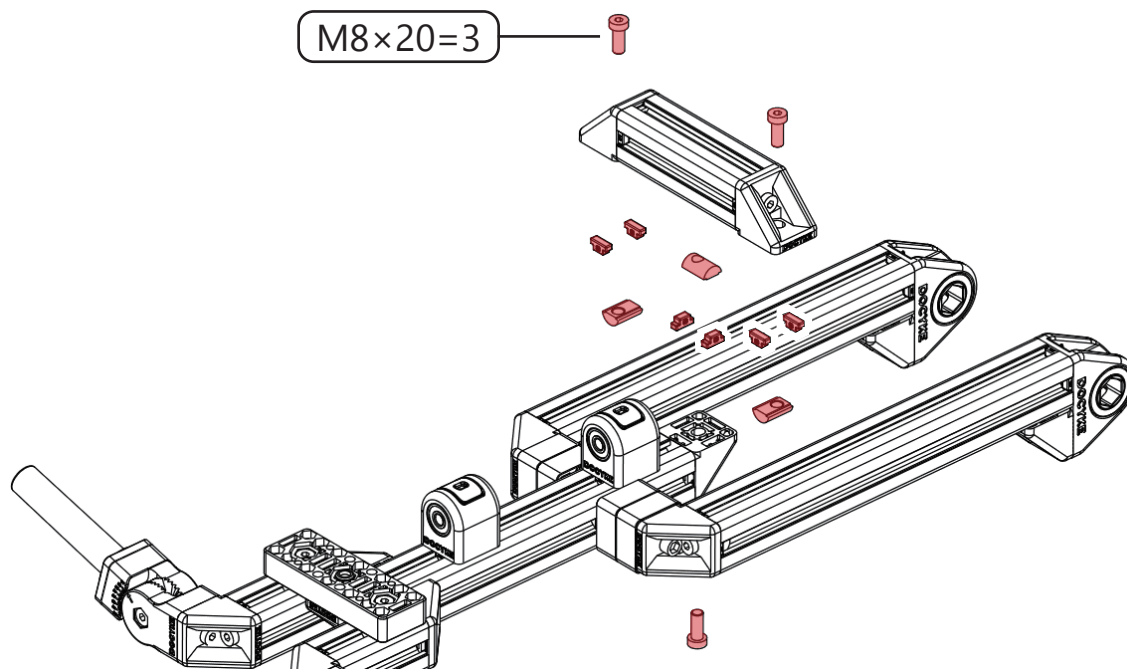

PART 1-2

A

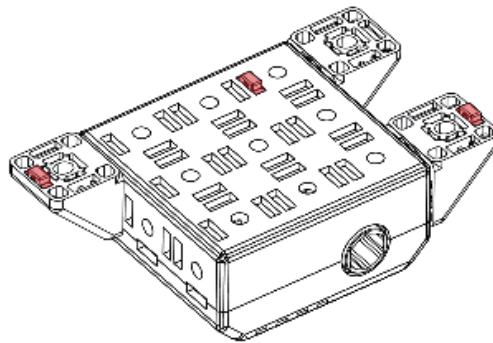
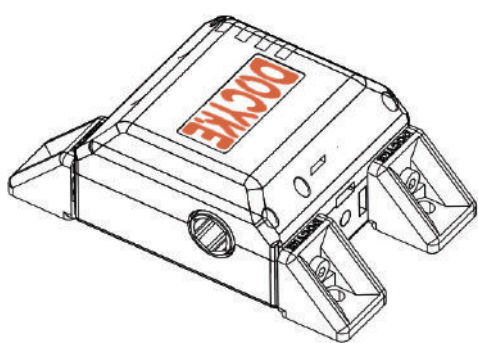
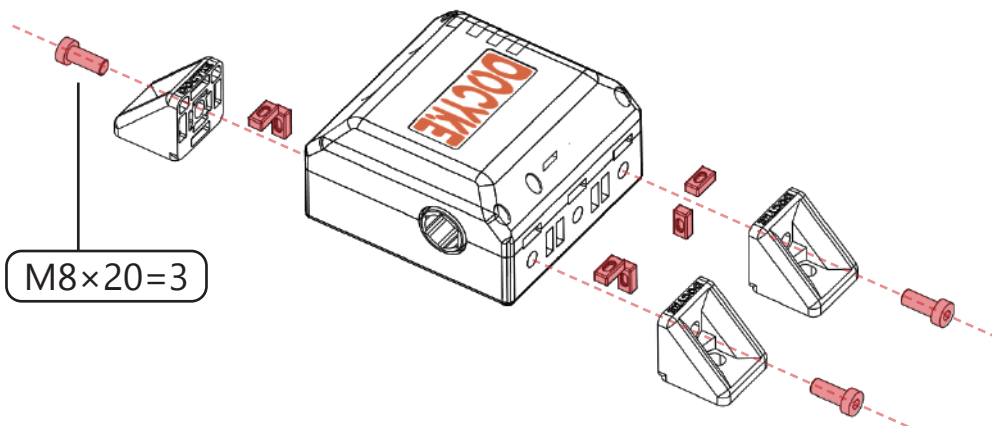

B

M8x20=3

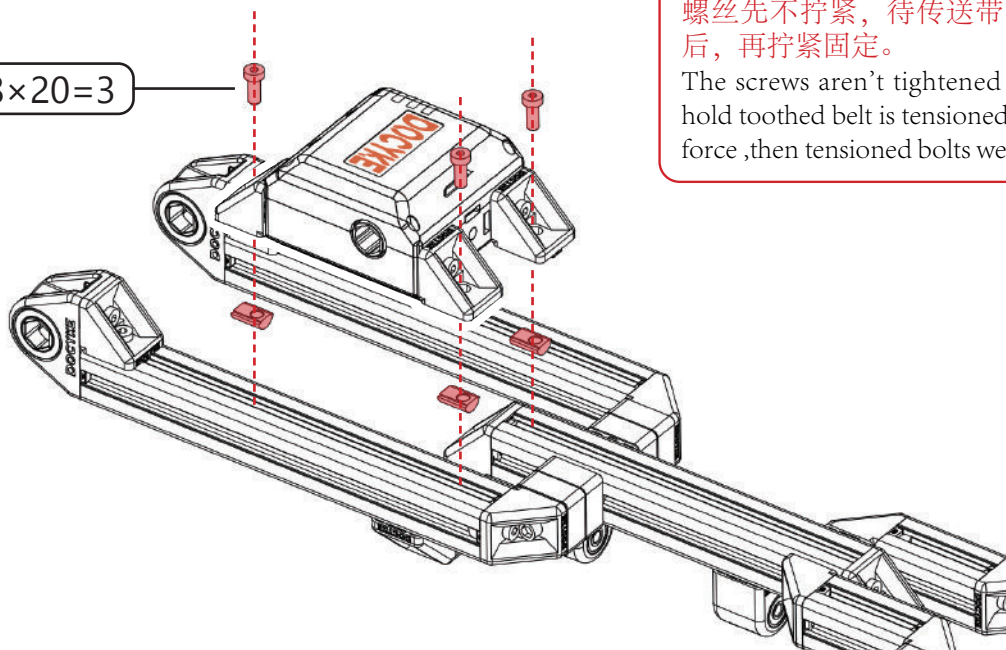

螺丝先不拧紧，待传送带拉紧后，再拧紧固定。

The screws aren't tightened until hold toothed belt is tensioned with force ,then tensioned bolts well.

C

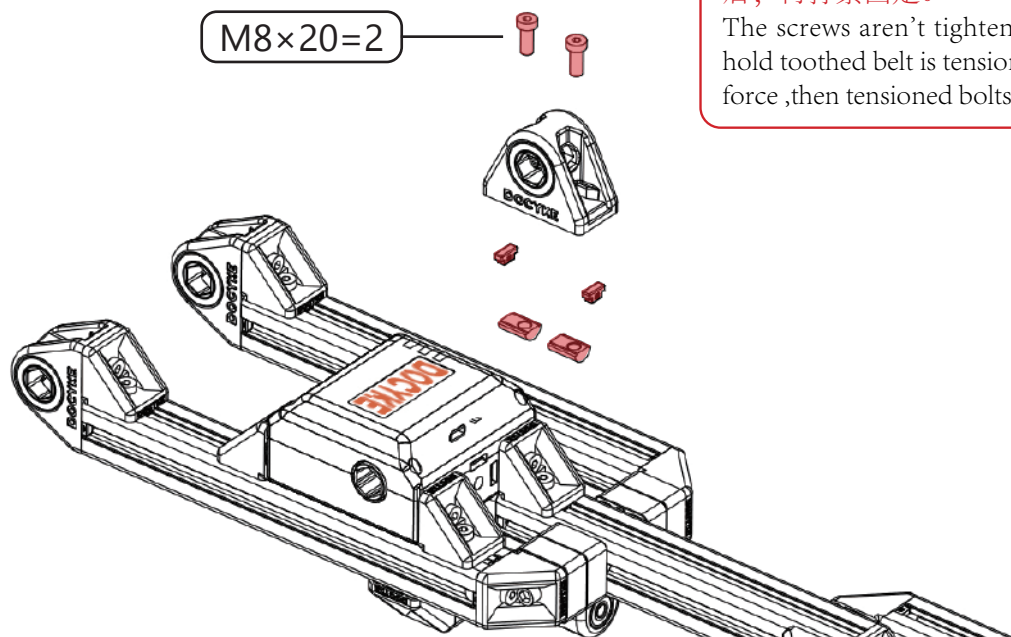

螺丝先不拧紧，待传送带拉紧后，再拧紧固定。

The screws aren't tightened until hold toothed belt is tensioned with force ,then tensioned bolts well.

D

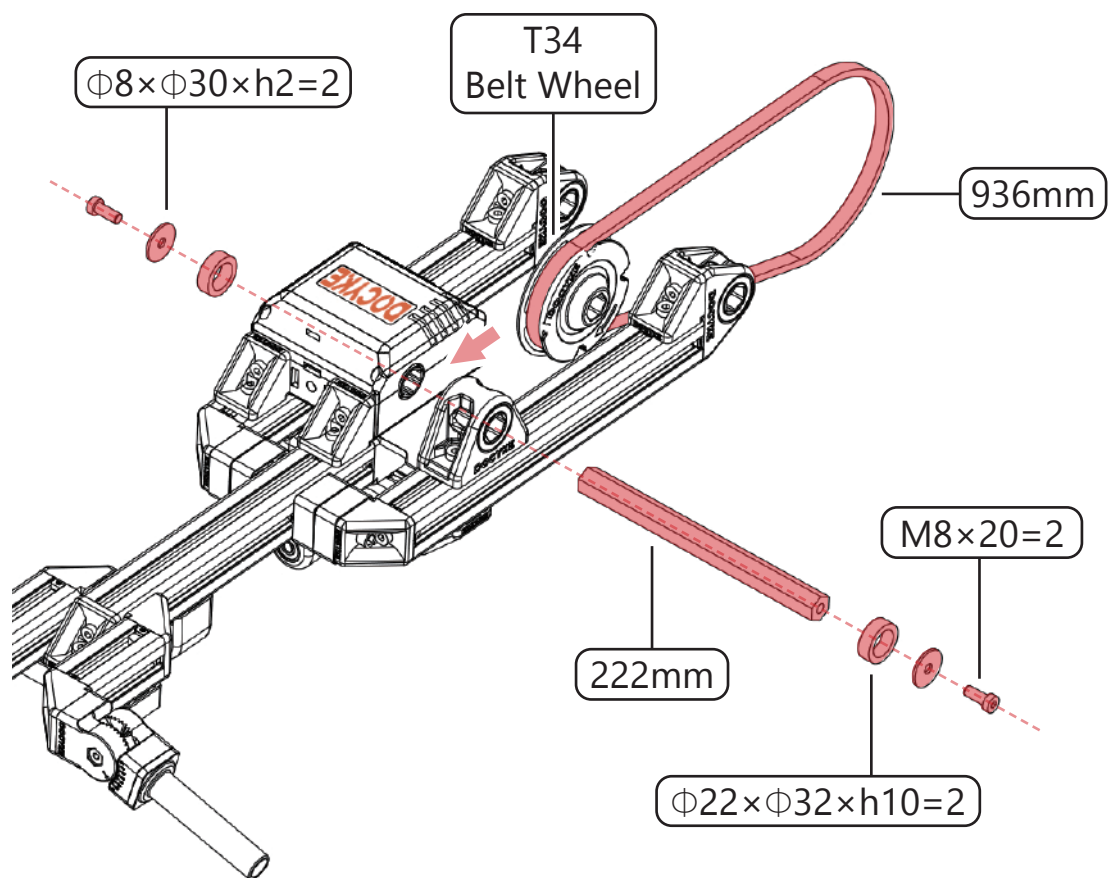

E

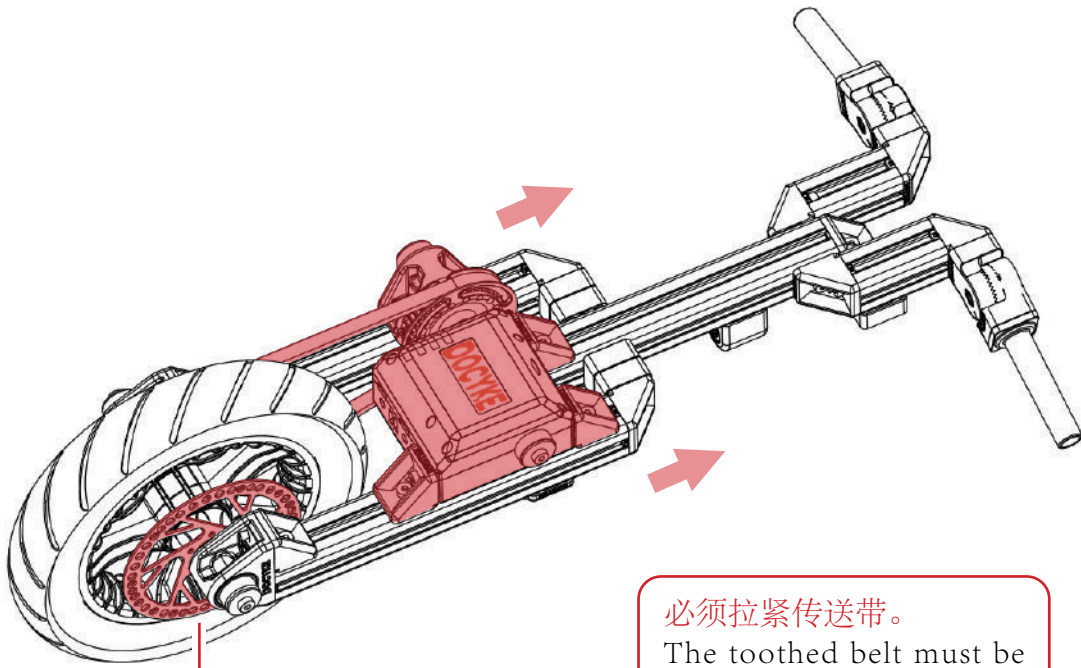
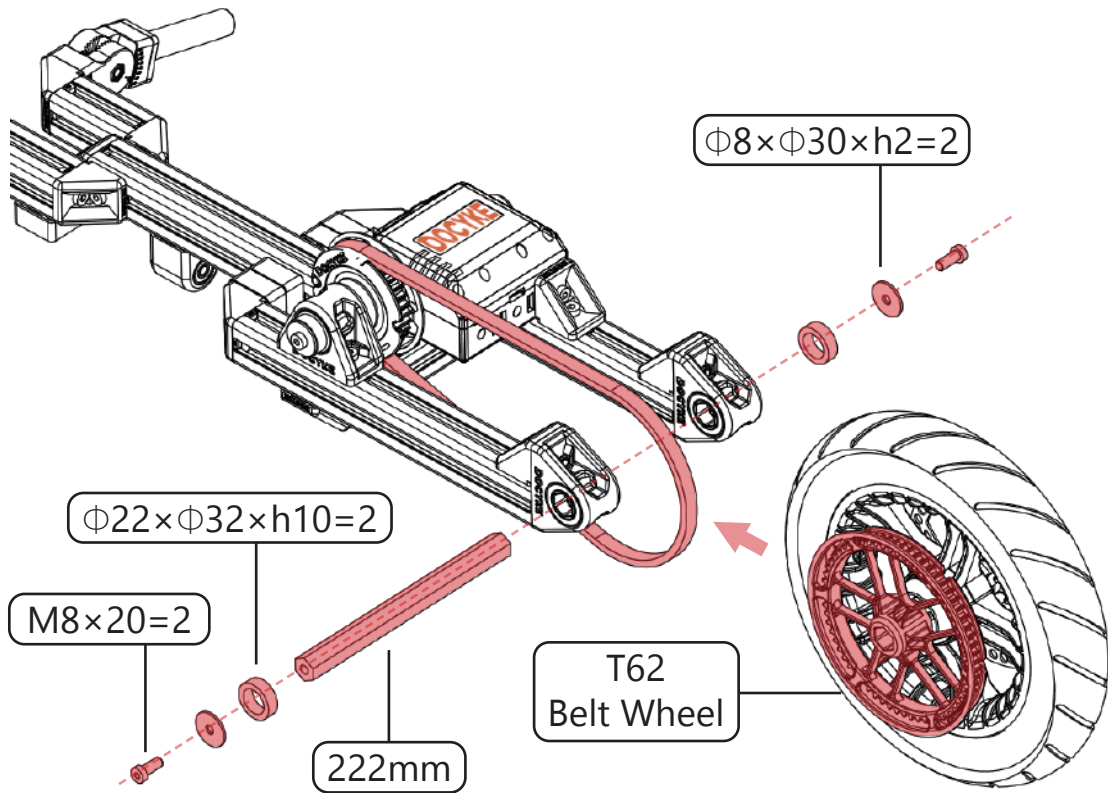

刹车盘
Brake disc

必须拉紧传送带。
The toothed belt must be tensioned.

F

- 具体操作详见第 38 页。
Specific operations on the page 38.

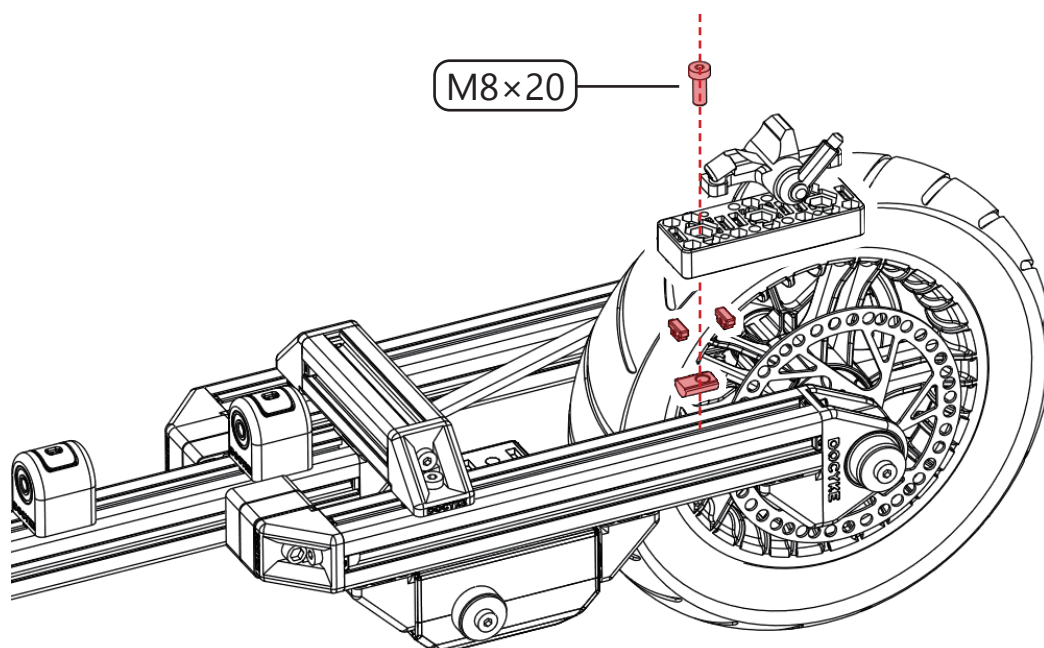

G

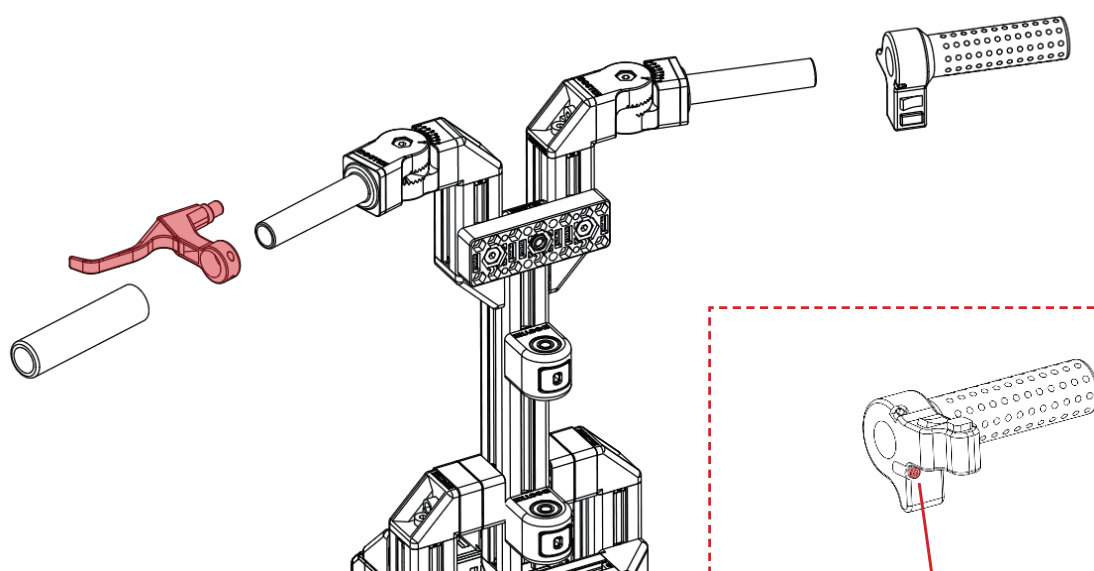

- 具体操作详见第 39 页。
Specific operations on the page 39.

拧紧螺钉固定调速把手。
Tighten the screws to secure the speed handle.

H

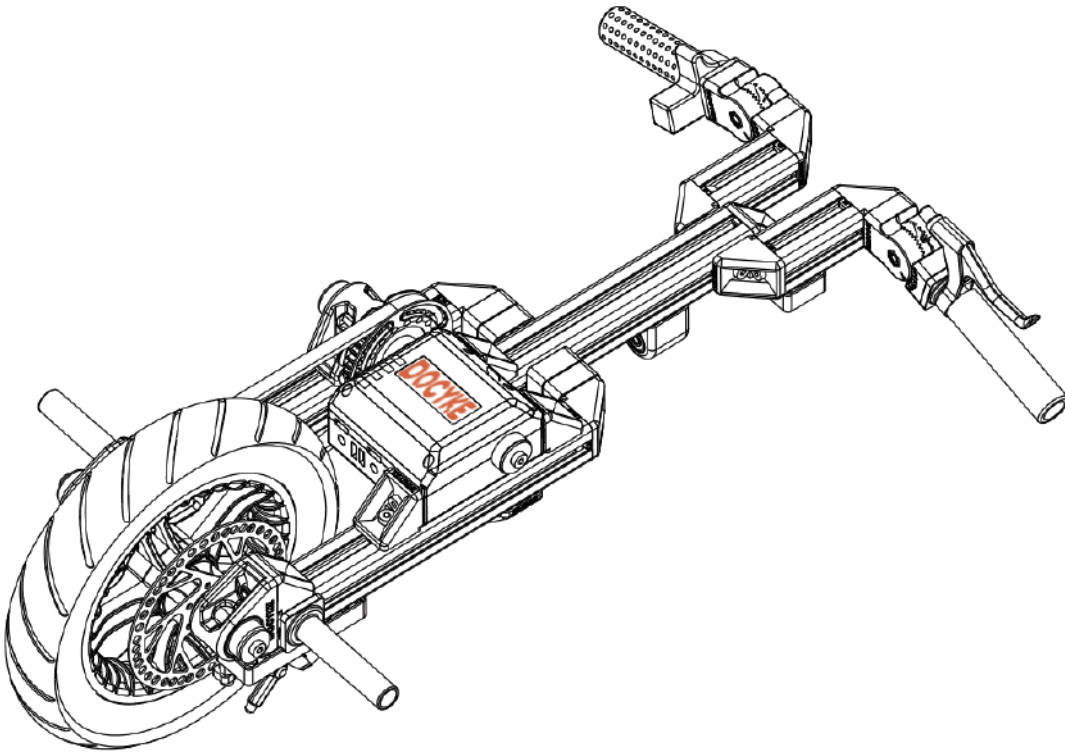
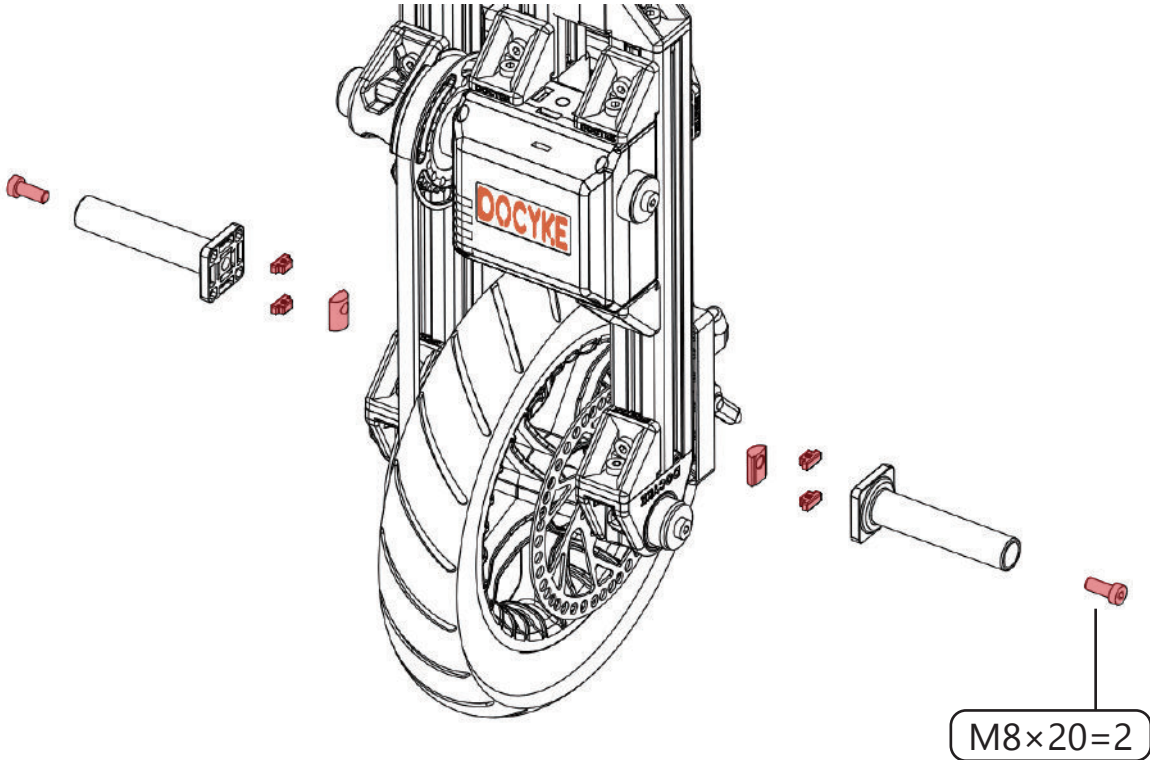

2 PART

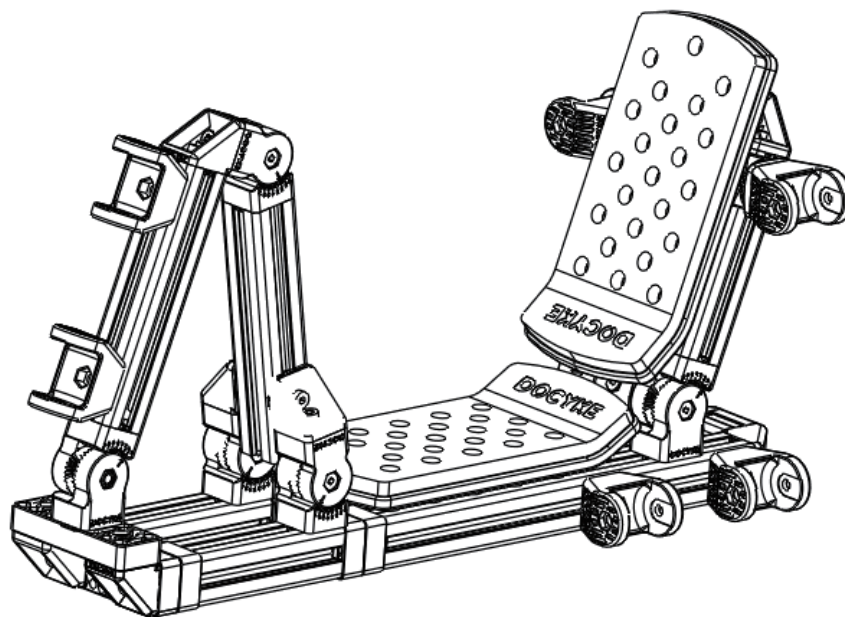

PART 2-1

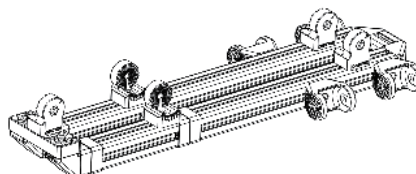

PART 2-2

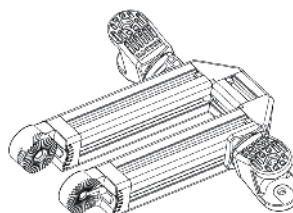

PART 2-3

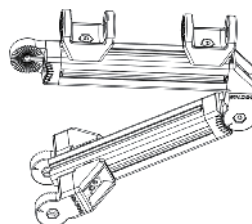

PART 2-1

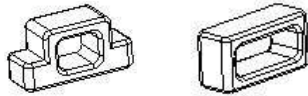
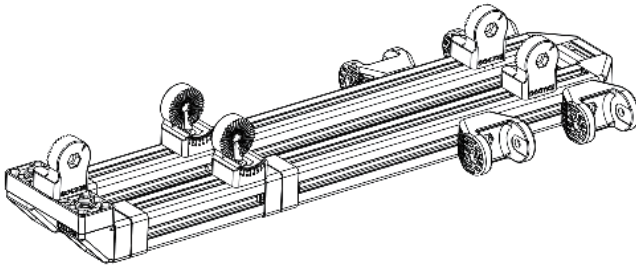

The positioning blocks are some of the smallest parts but they also some of the most important. Putting them in the right place is a key of the product.

产品中一共包含两种定位块，它是至关重要的部件，请仔细分辨。几乎所有零件的装配都会使用到他们，请务必按照说明使用，避免漏装或误装。

A

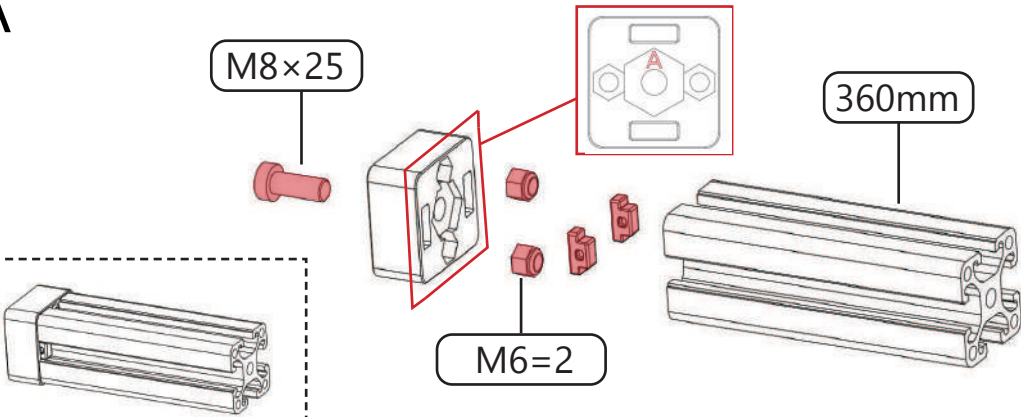

B

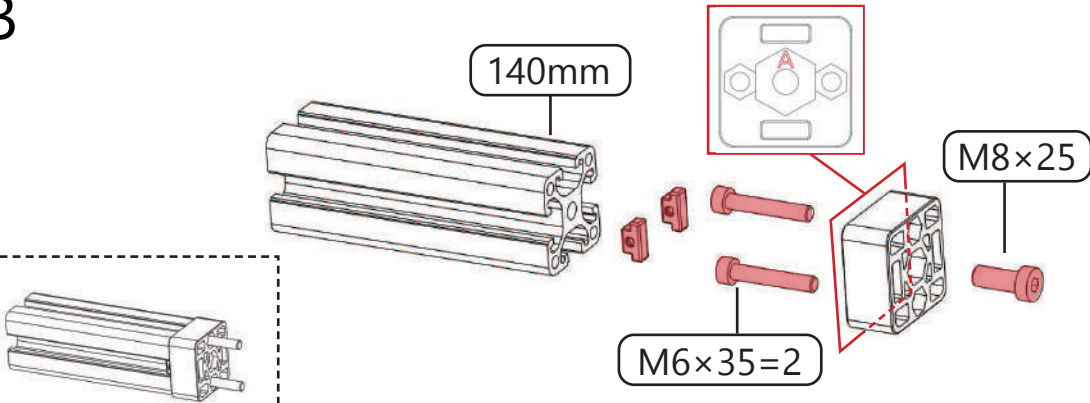

C

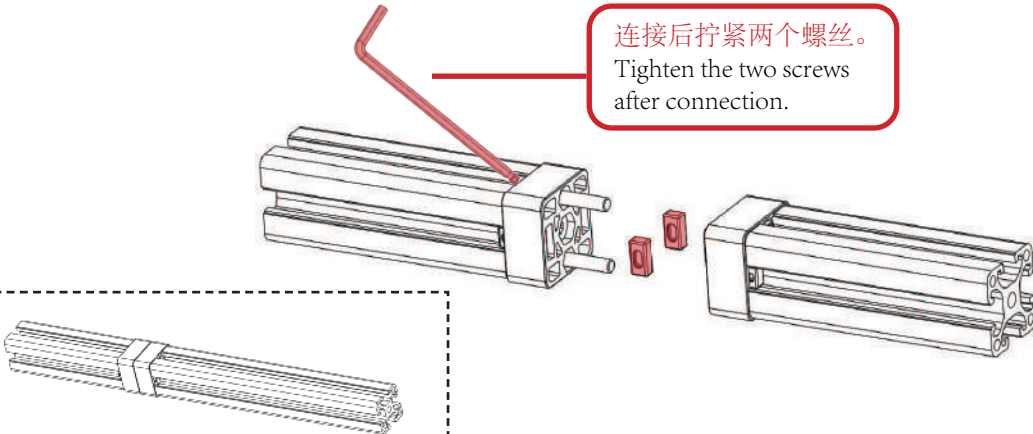

D

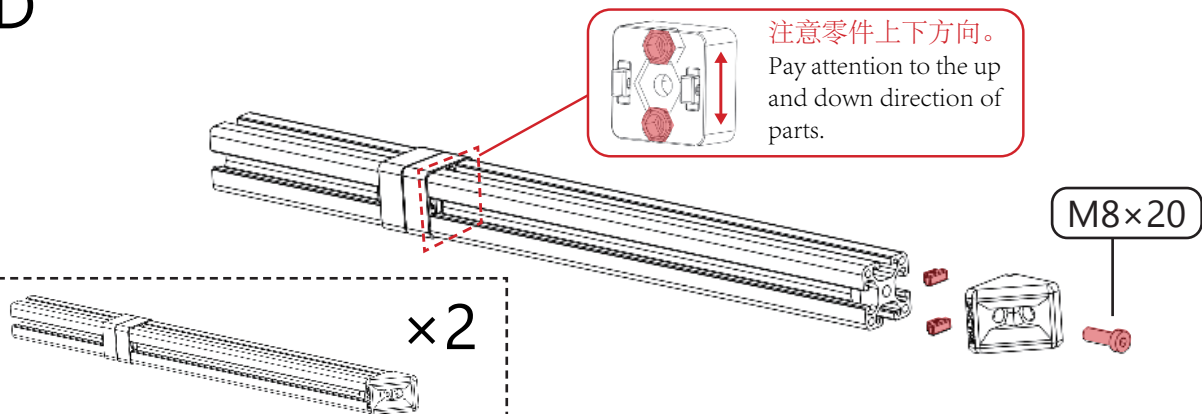

E

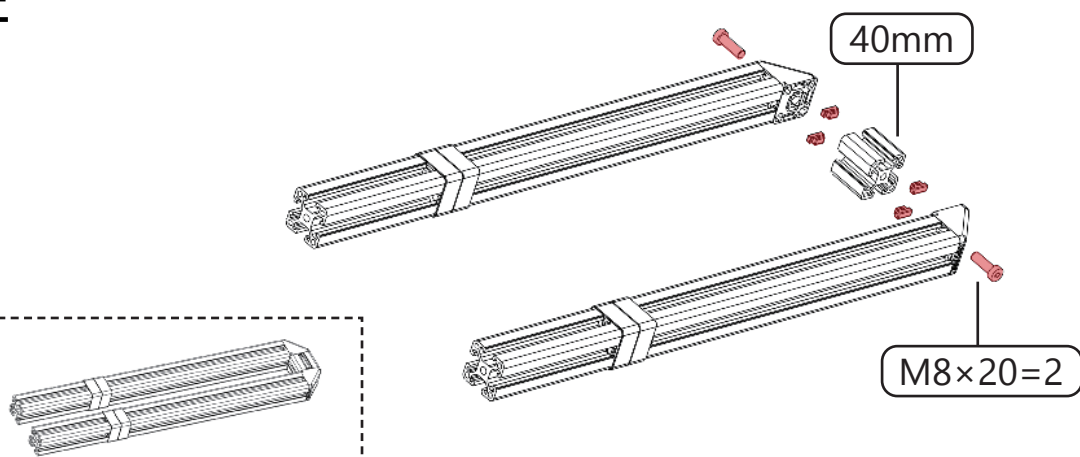

F

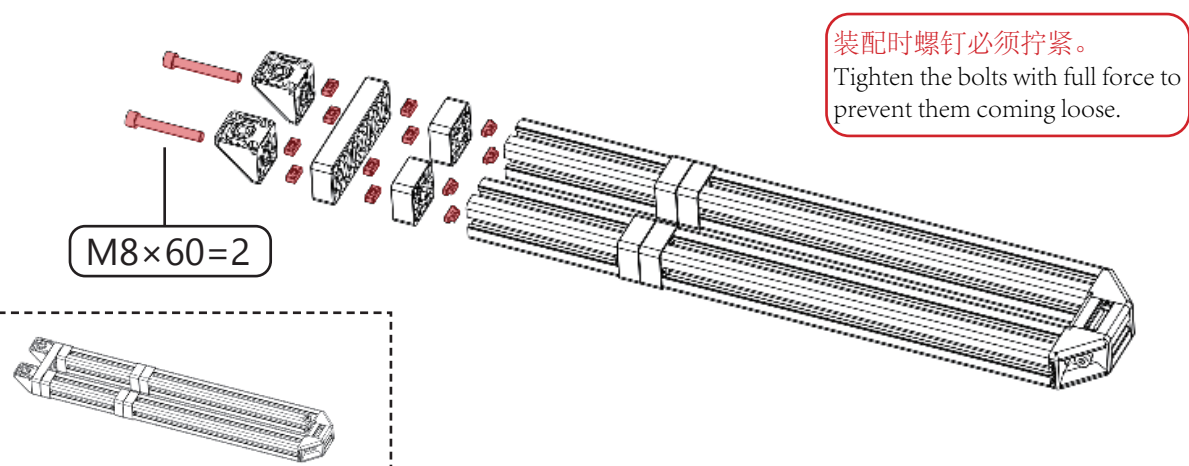

G

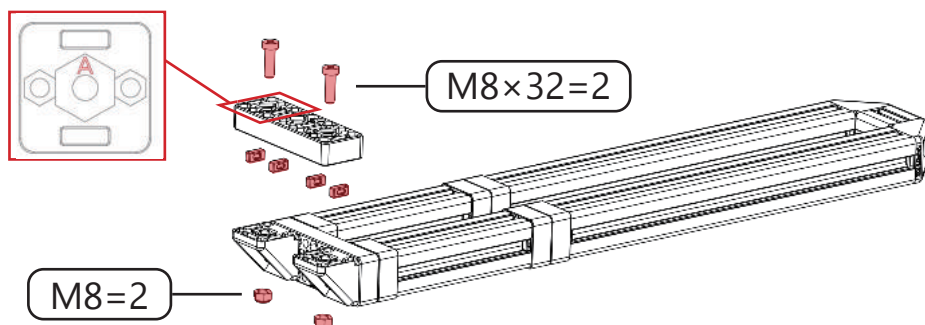

H

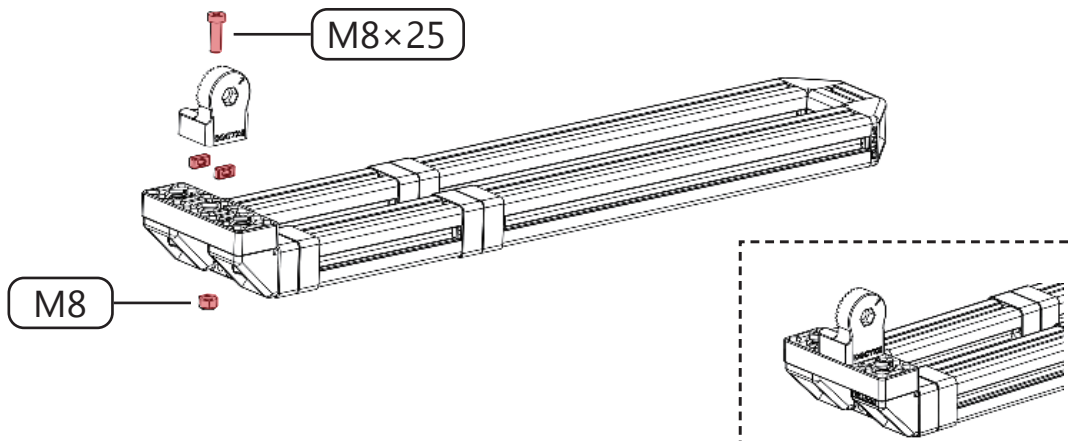

I

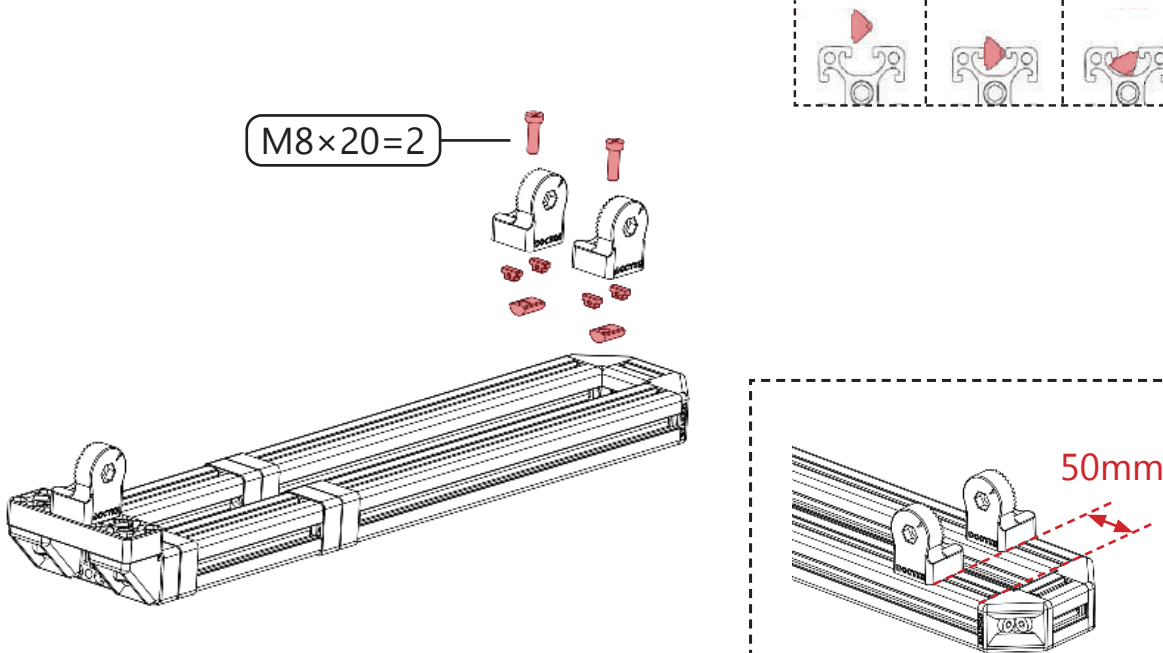

J

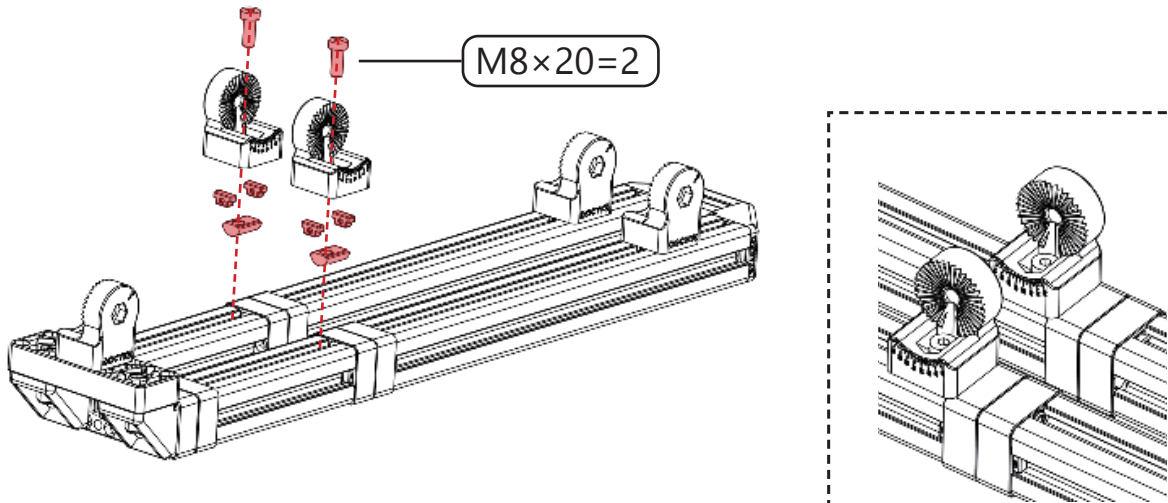

DOCYKE

K

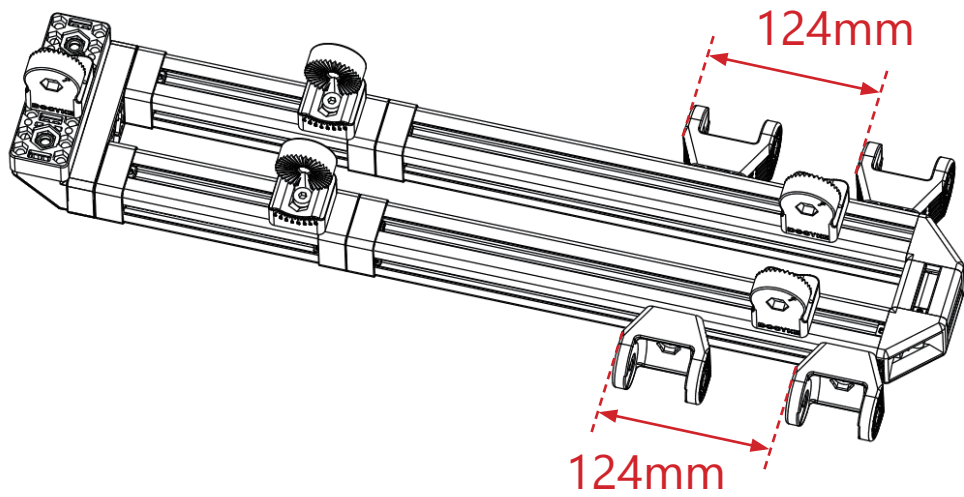
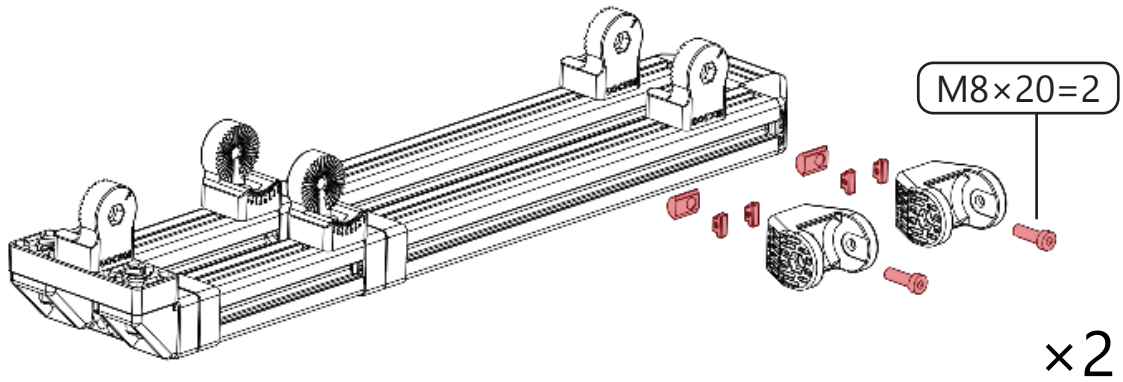

PART 2-2

A

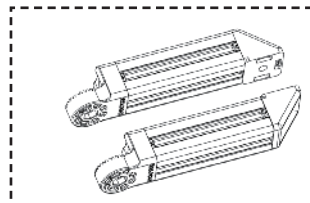
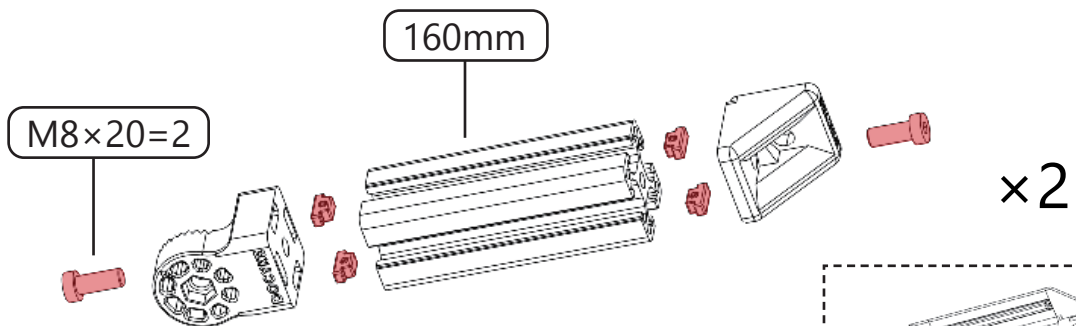

B

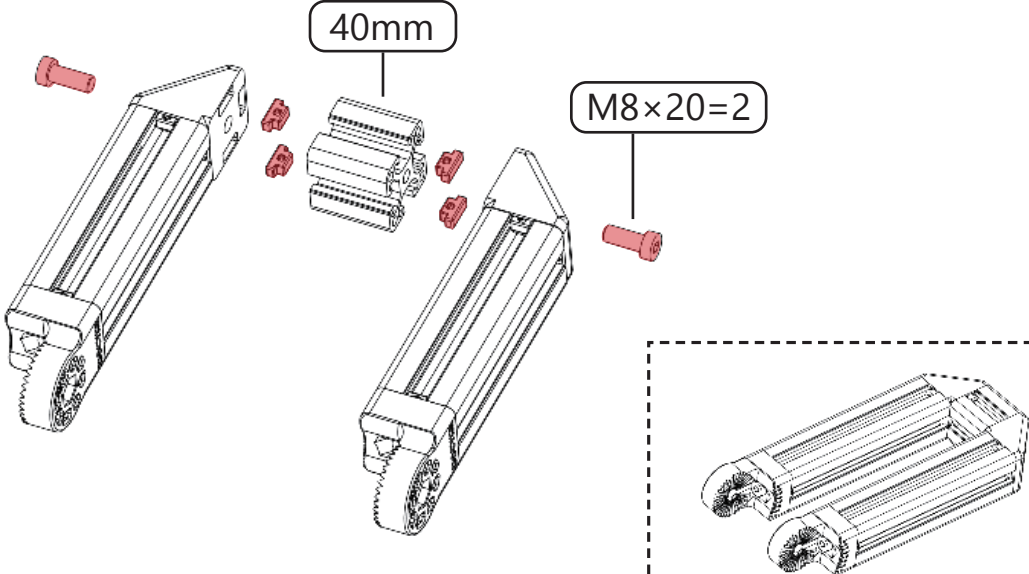

C

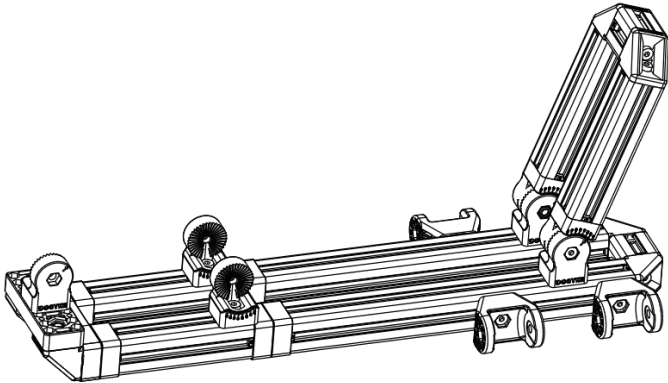
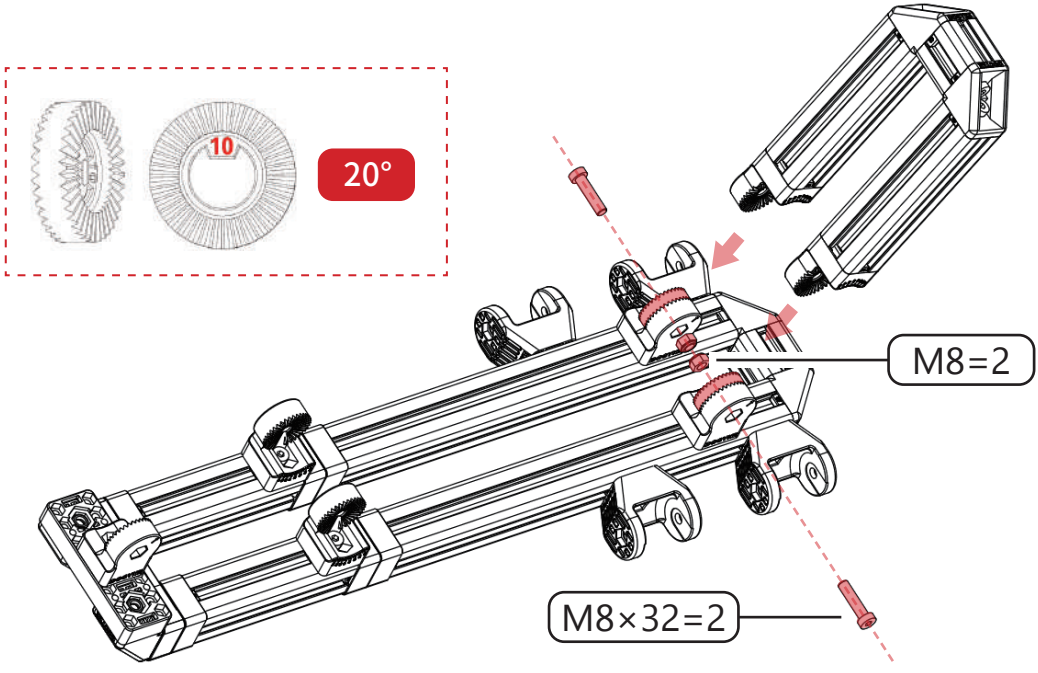

DOCYKE

PART 2-3

A

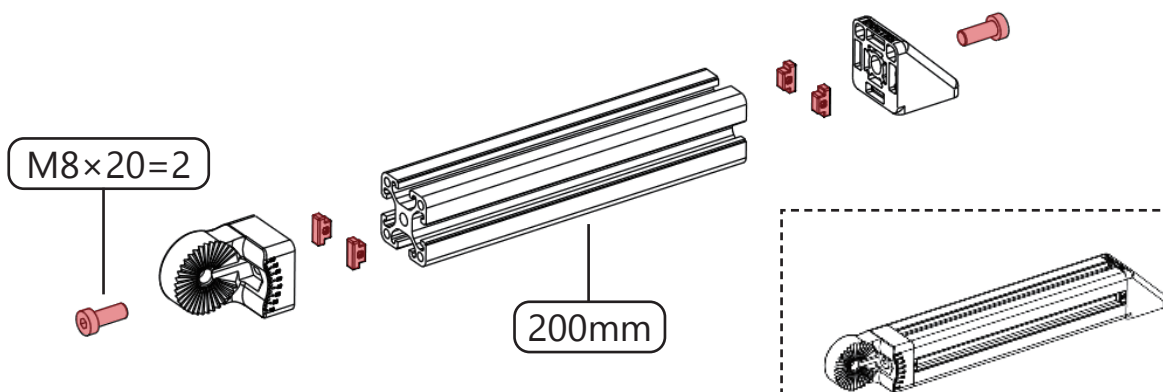

B

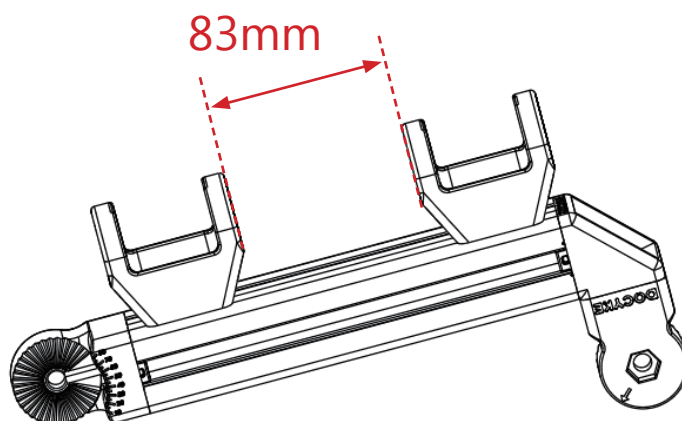
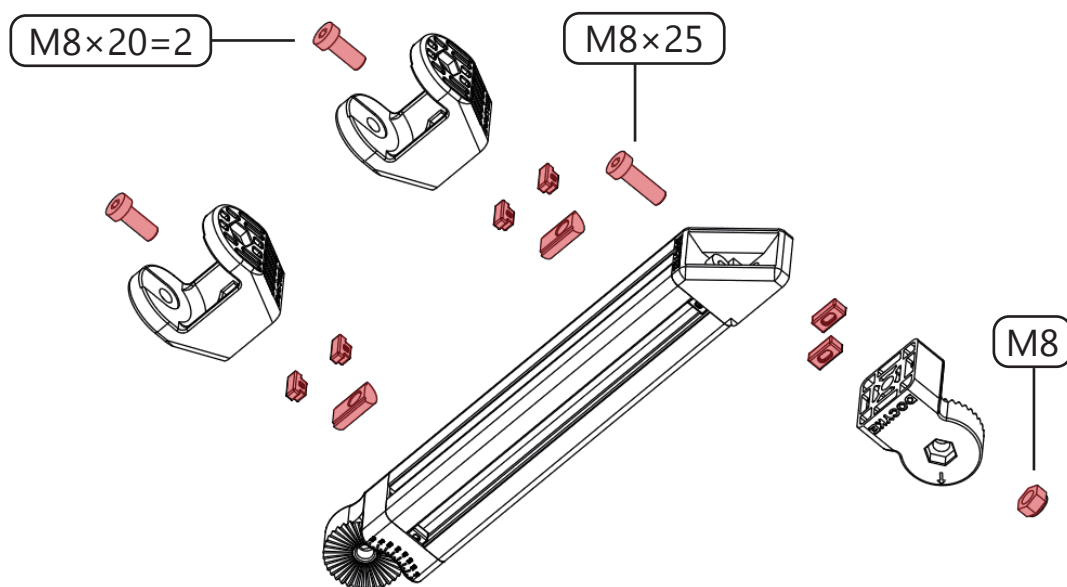

C

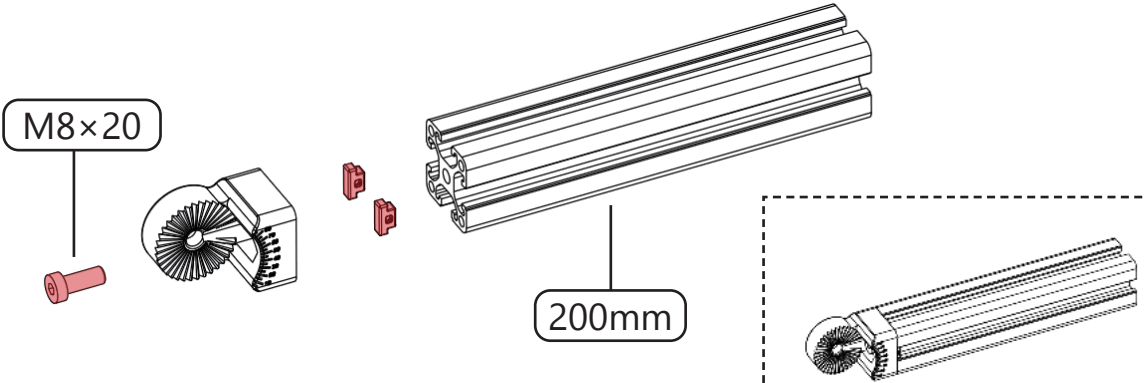

D

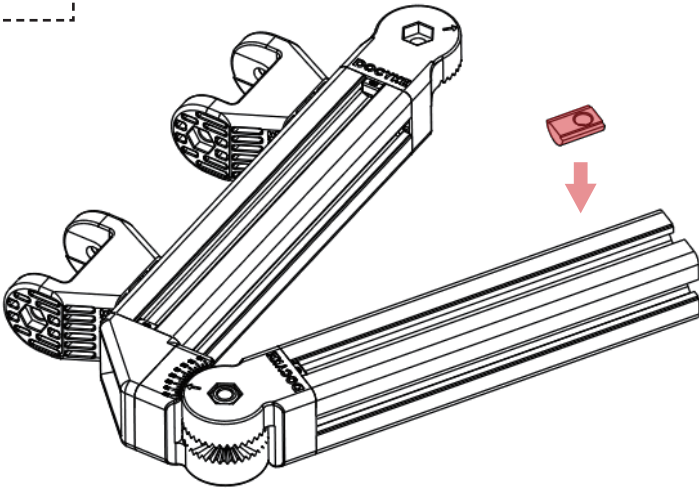
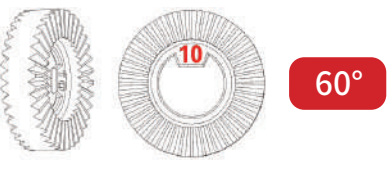
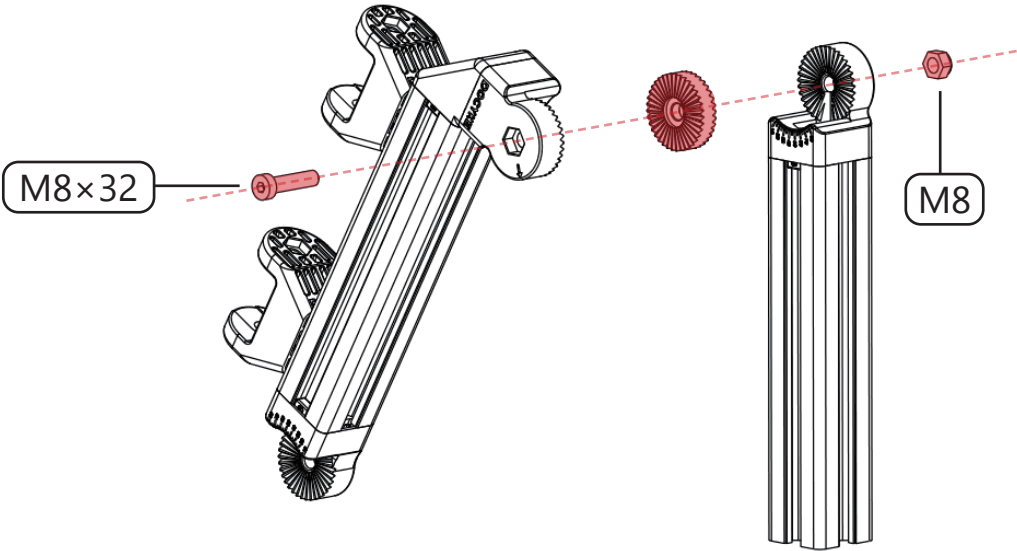

E

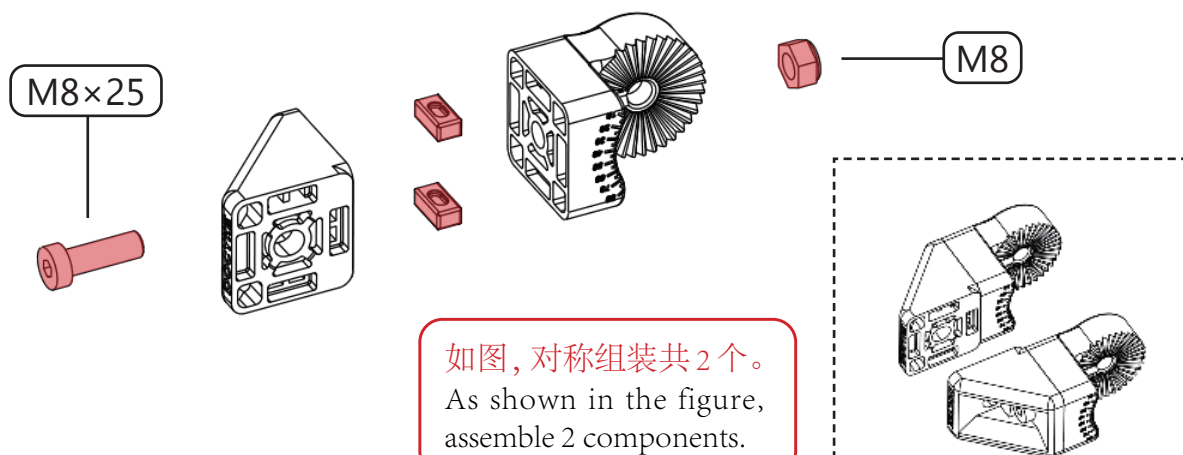

F

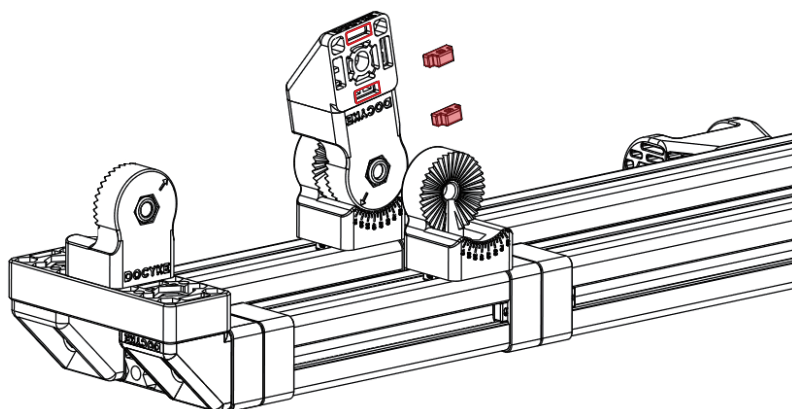
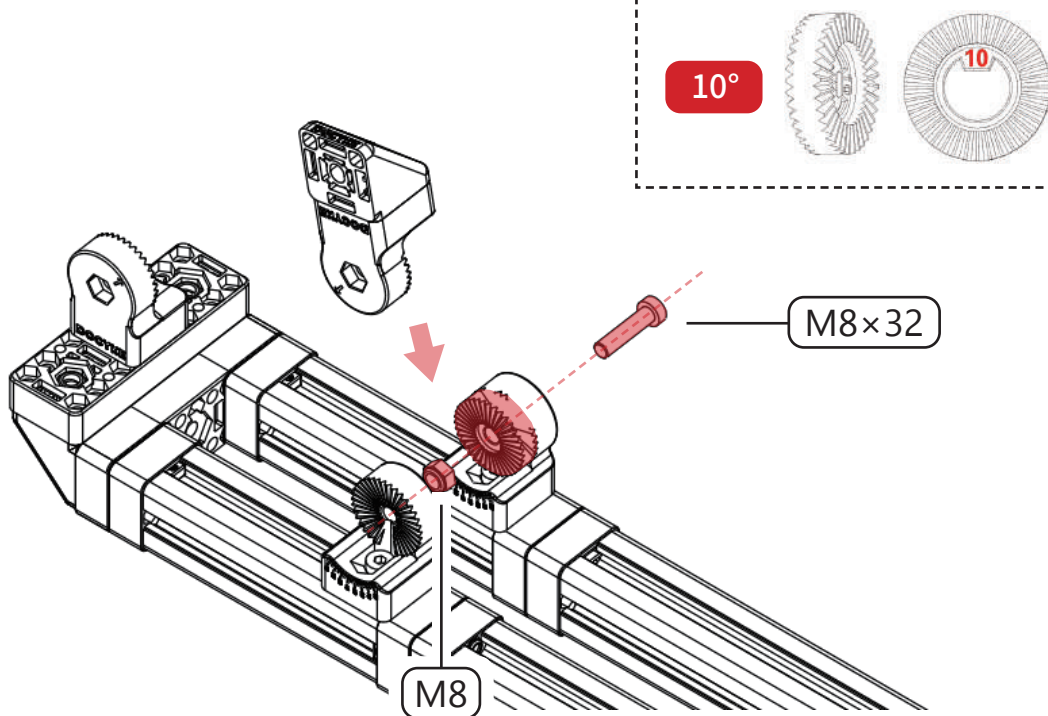

G

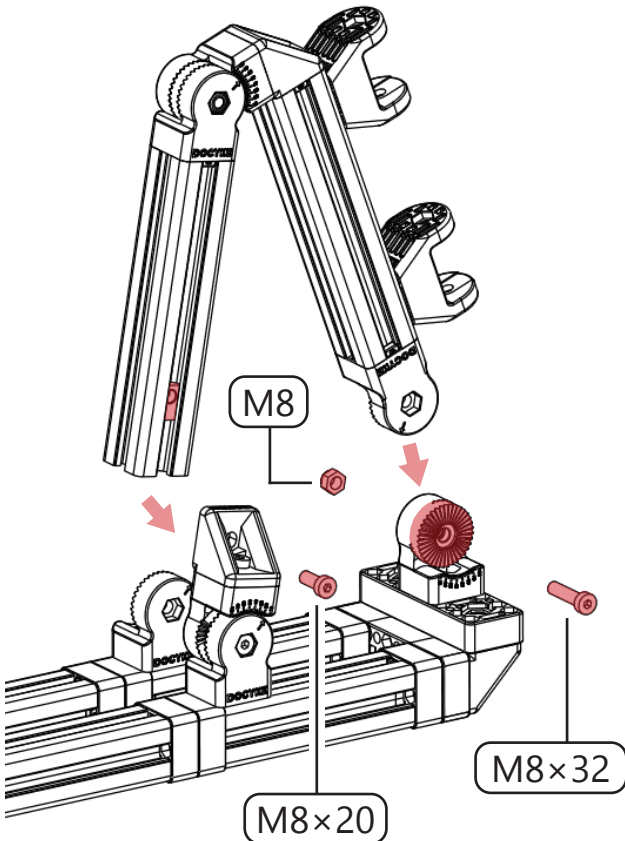

20°

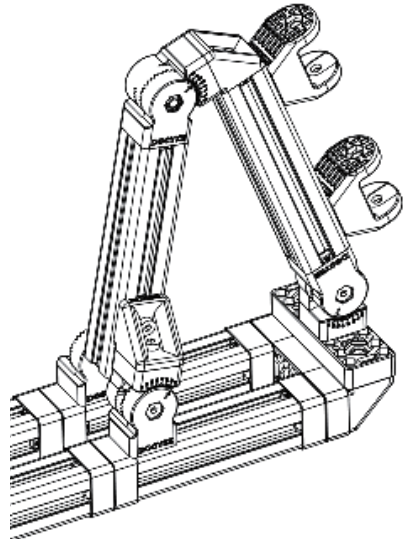
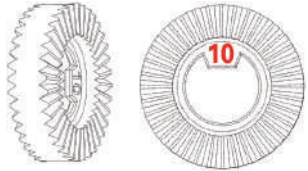

H

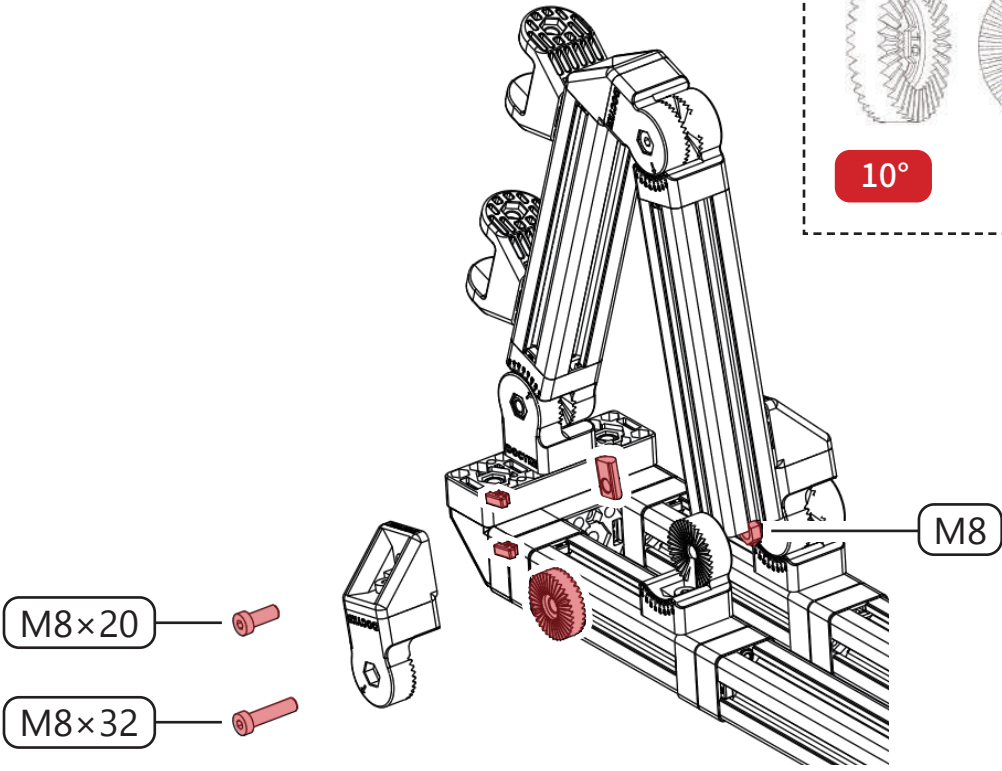

10°

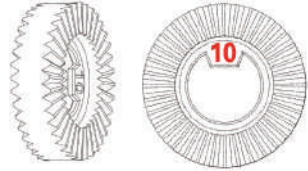

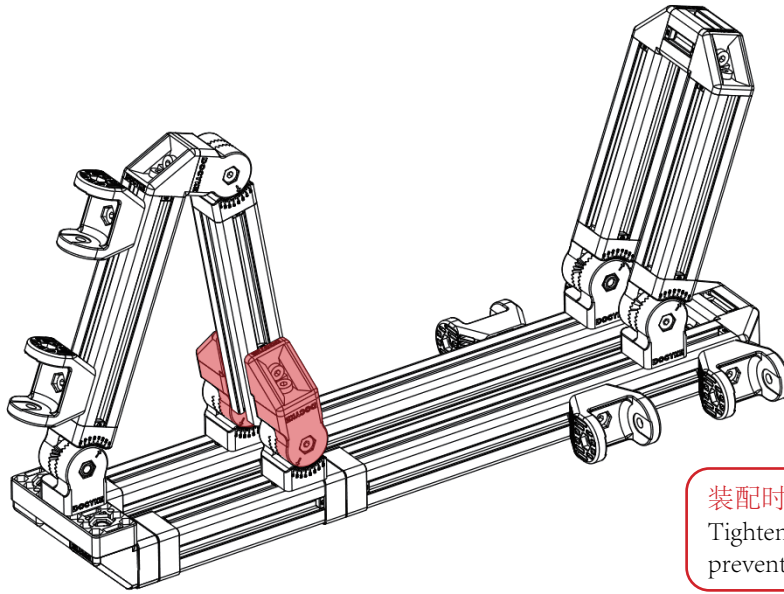

装配时螺钉必须拧紧。
Tighten the bolts with full force to prevent them coming loose.

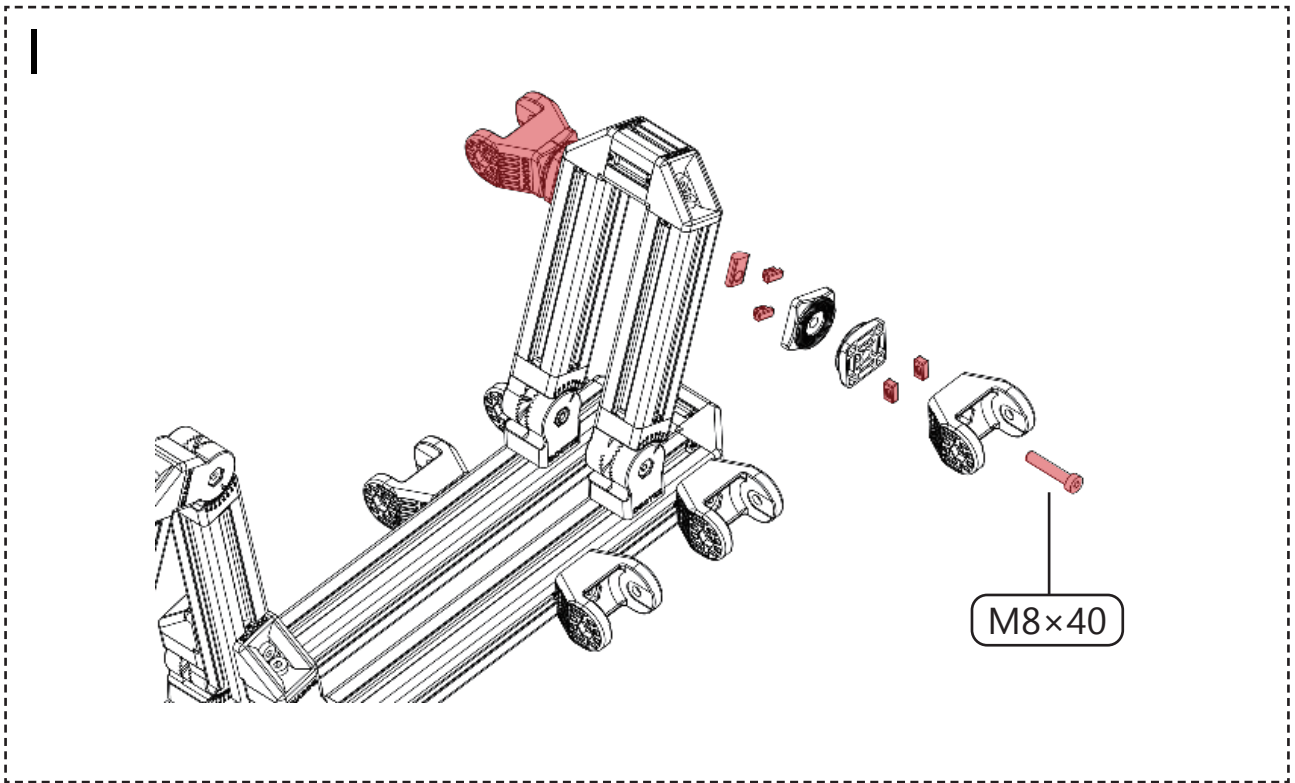

平面齿座每个刻度是 10° , 每转一格最小单位是 5° 。

Toothed-joint :Each scale is 10° , and each increment is 5° .

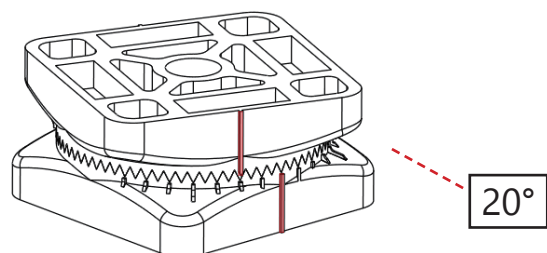
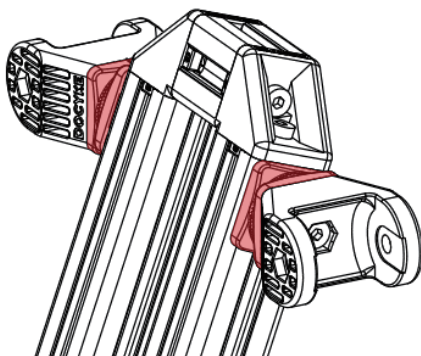

3 PART

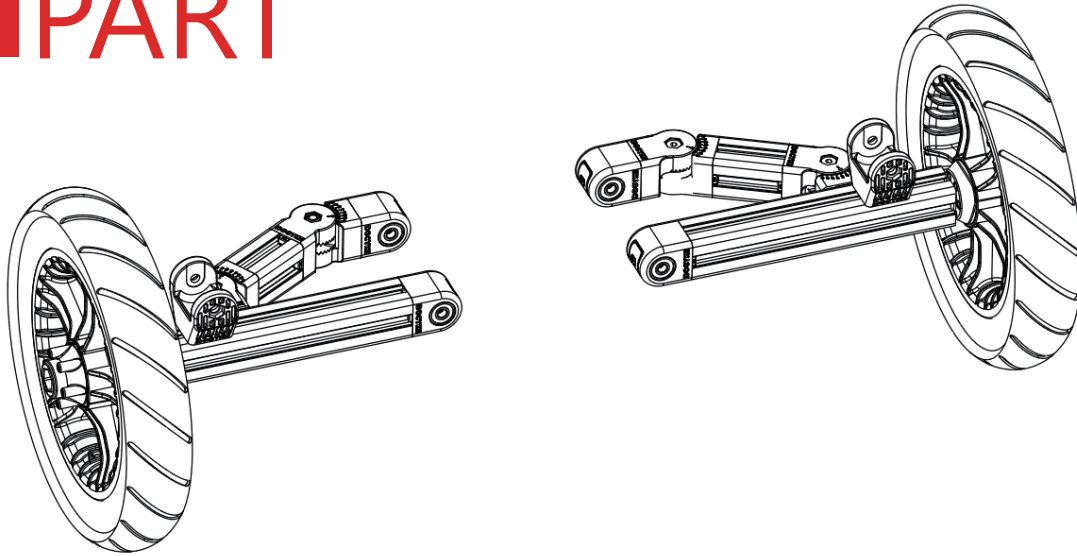

A

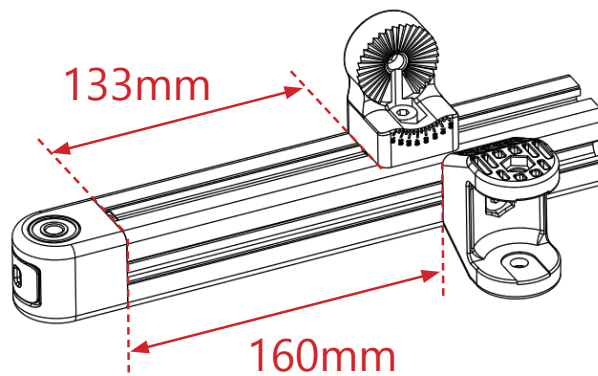
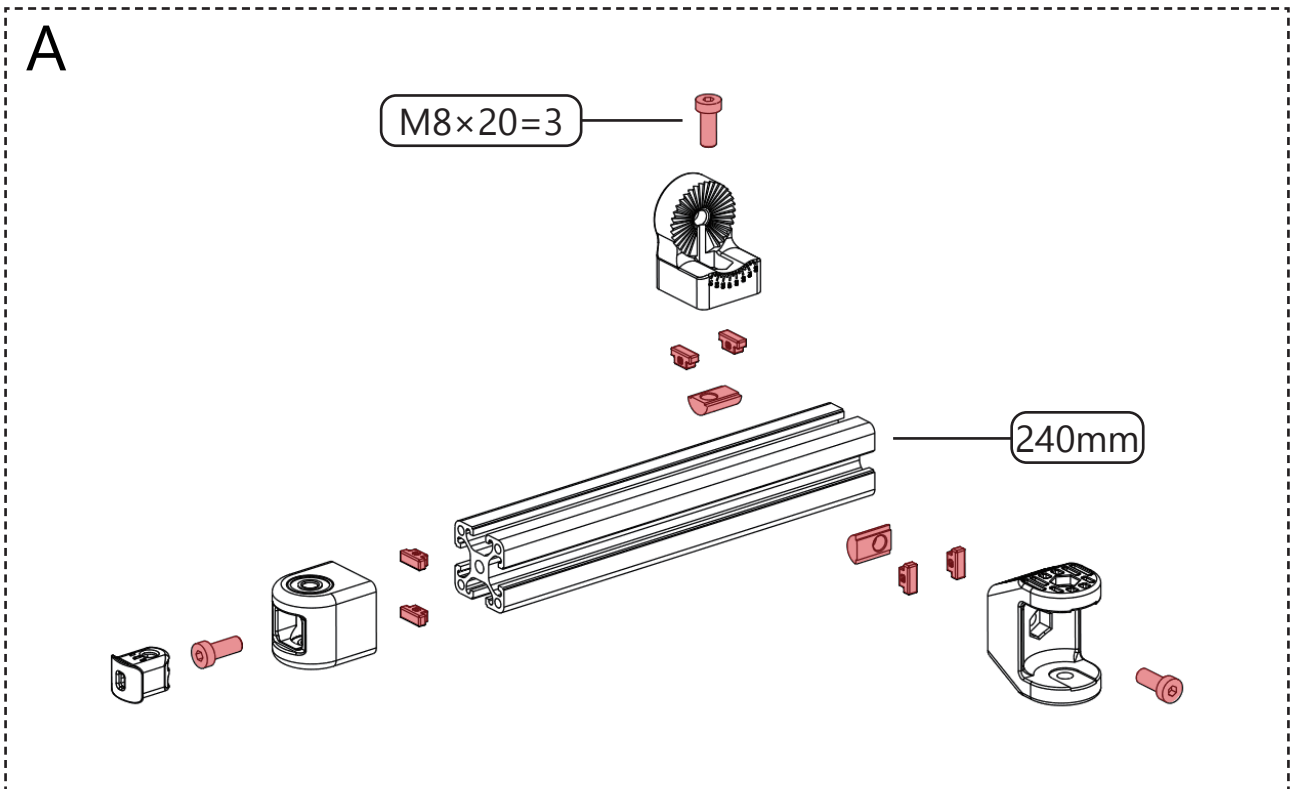

DOCYKE

B

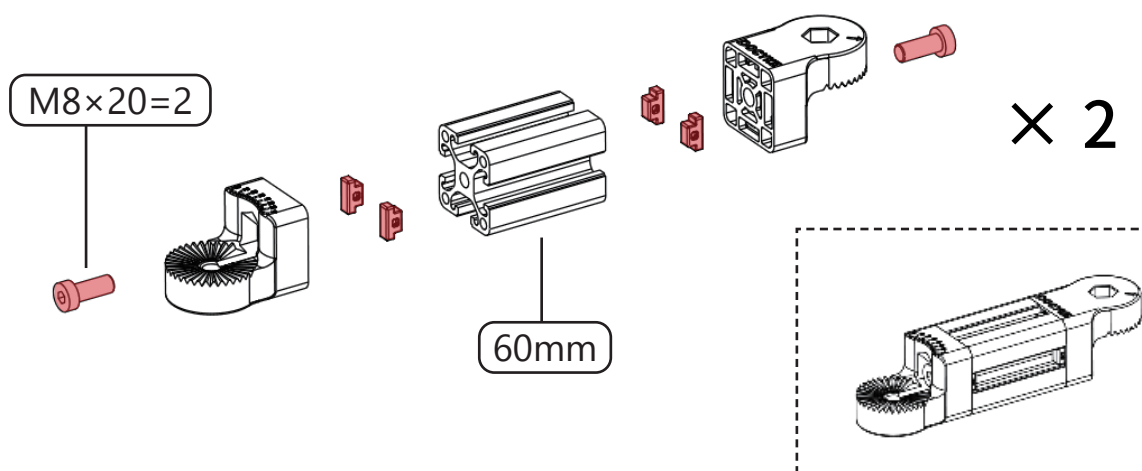

C

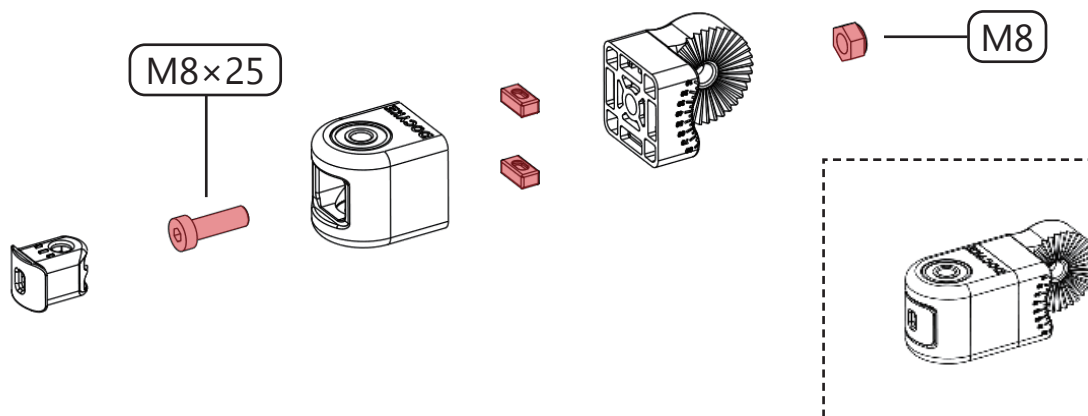

D

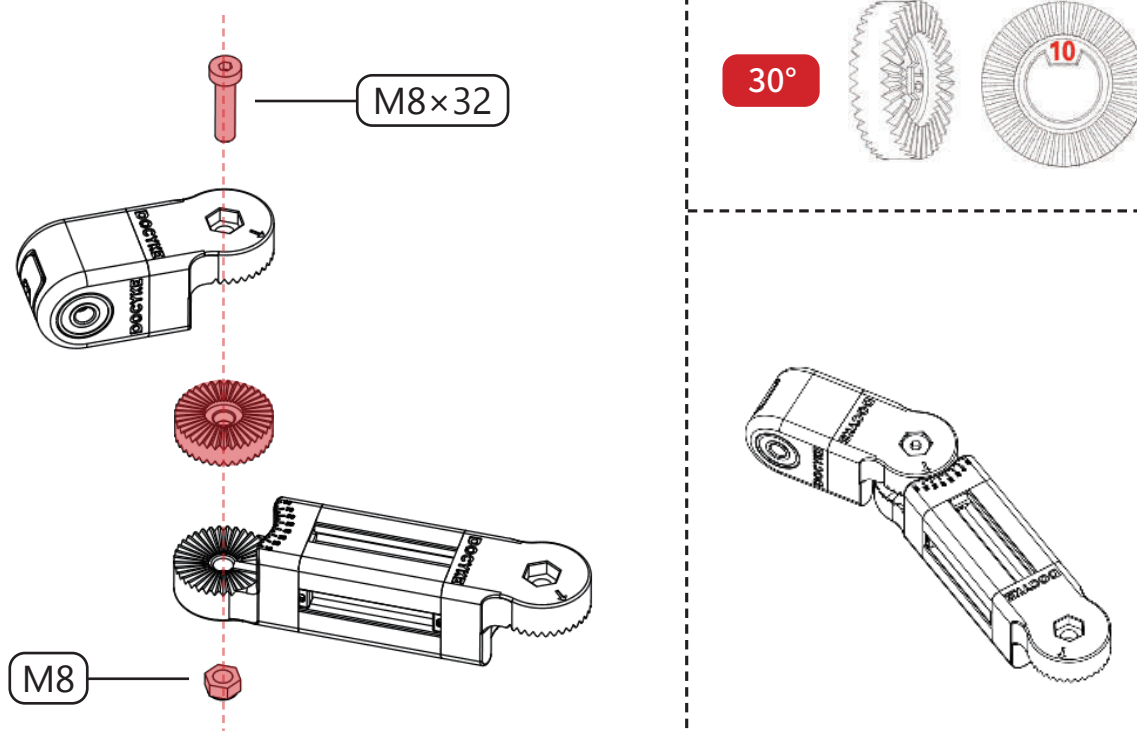

E

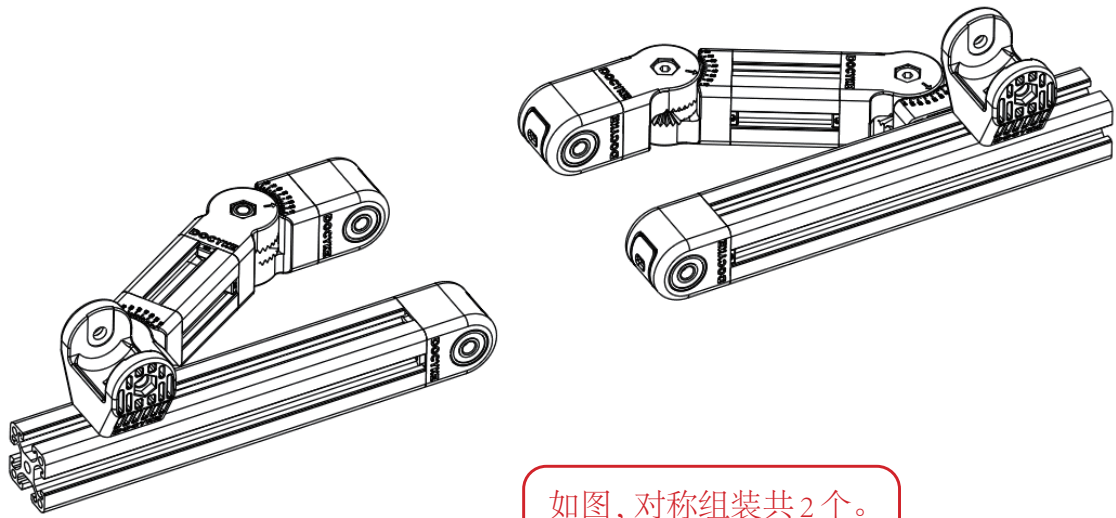
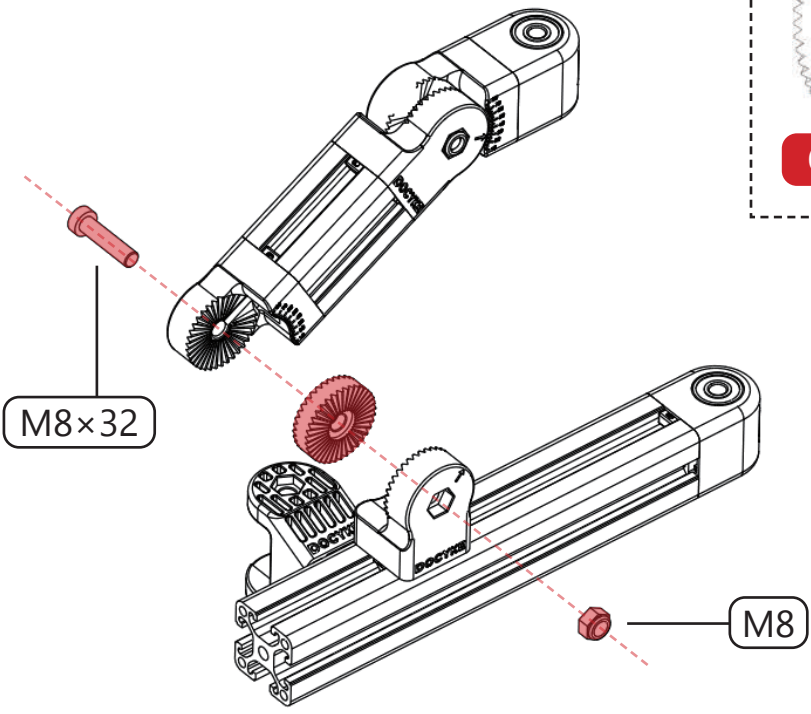

如图, 对称组装共 2 个。
As shown in the figure,
assemble 2 components.

F

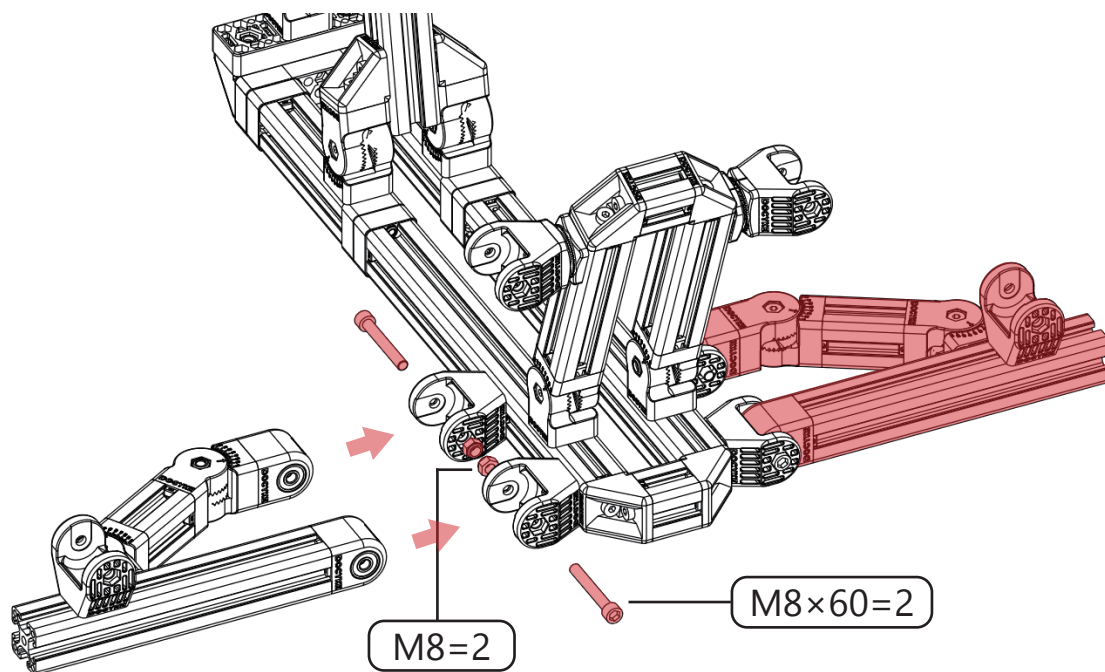

G

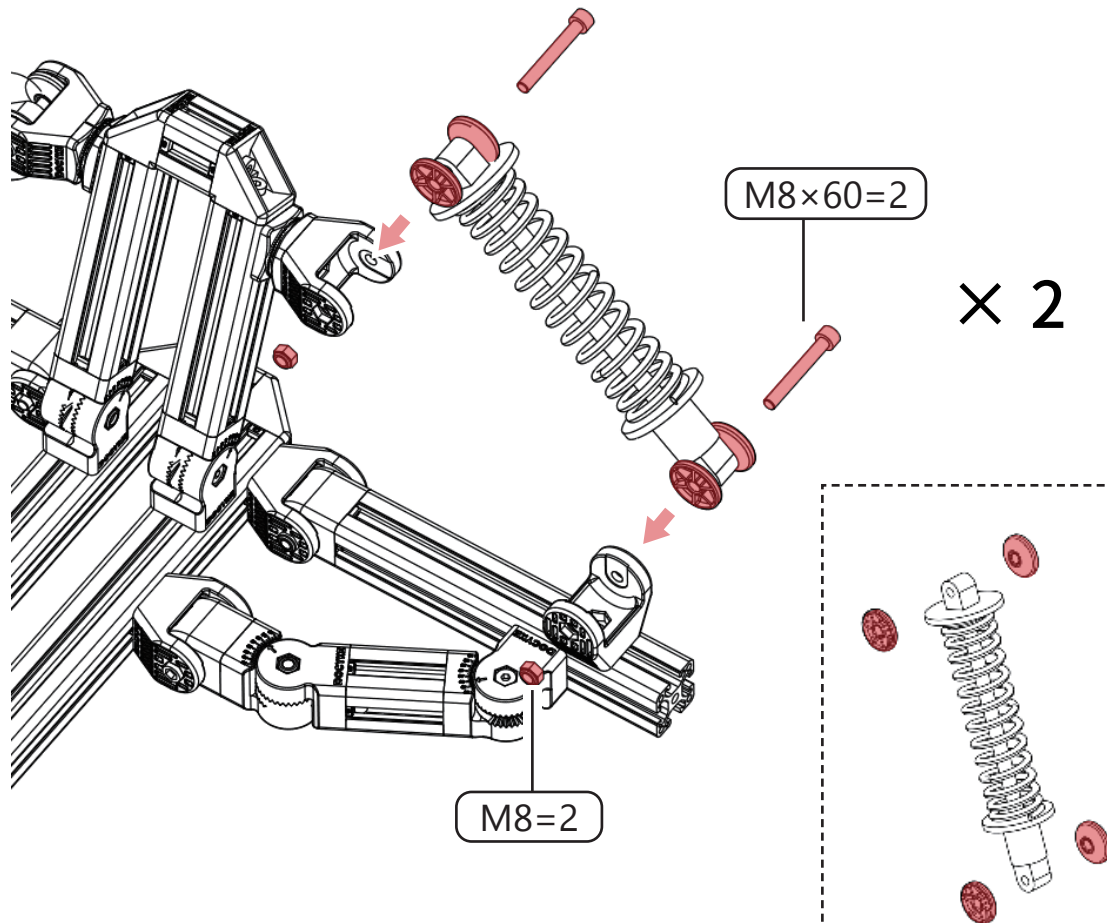

H

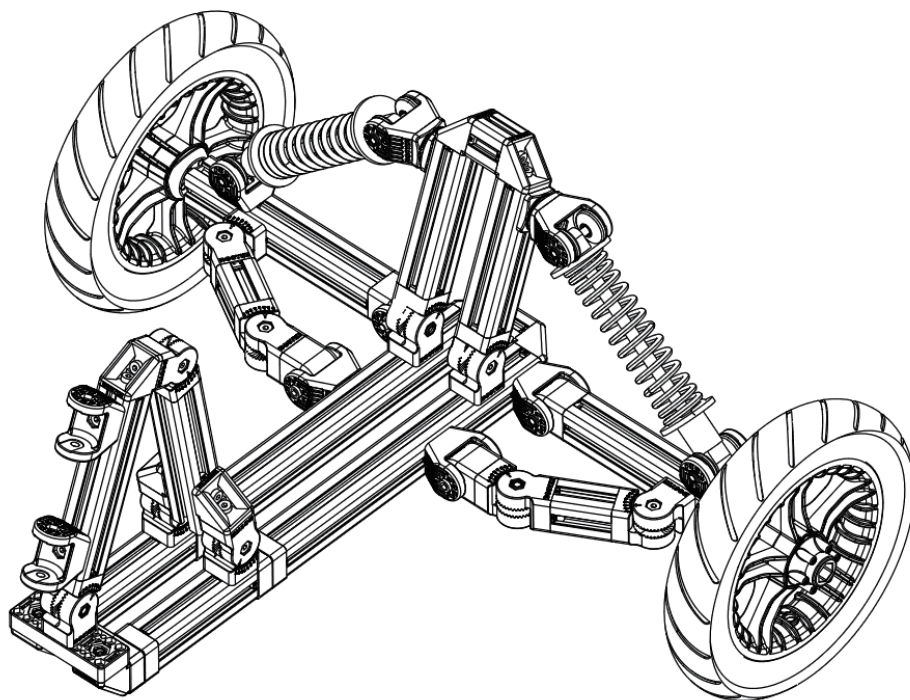
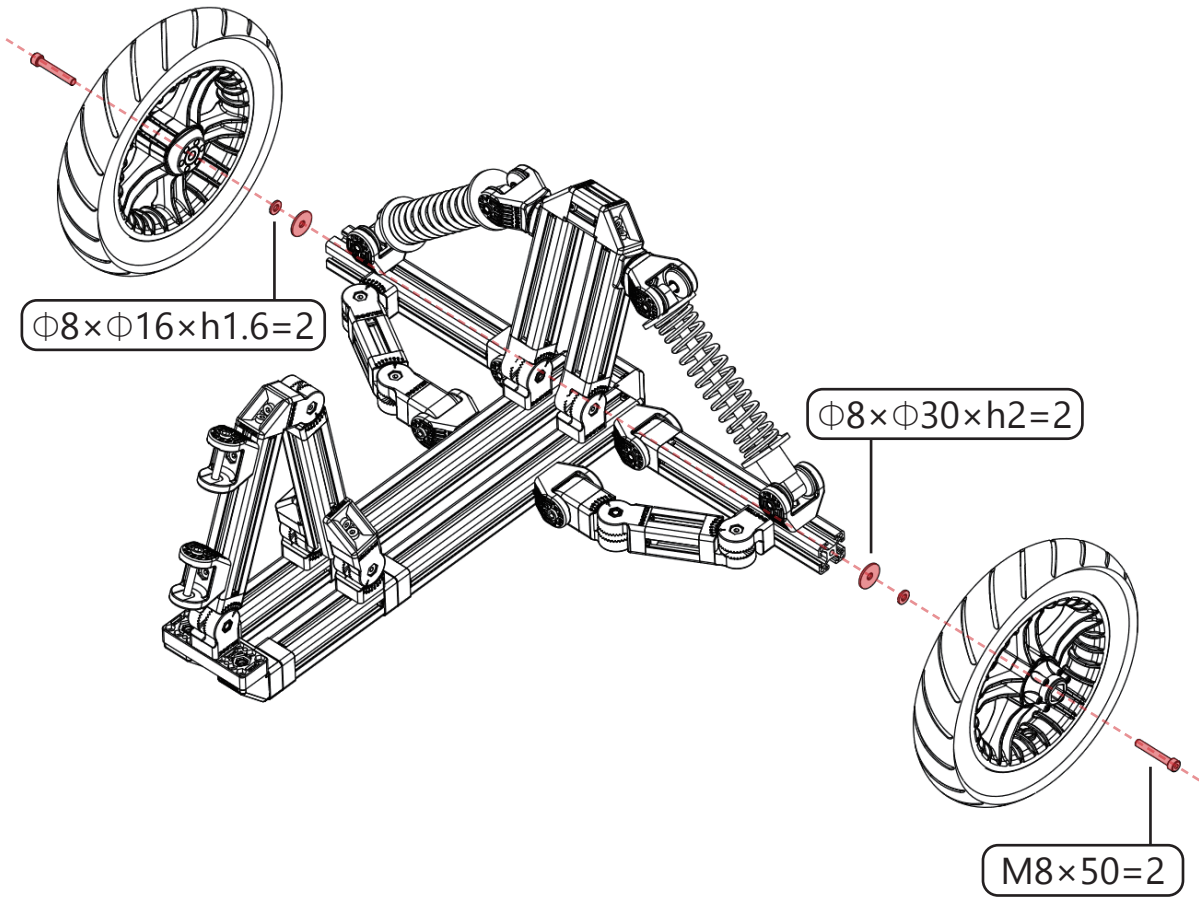

ASM.

A

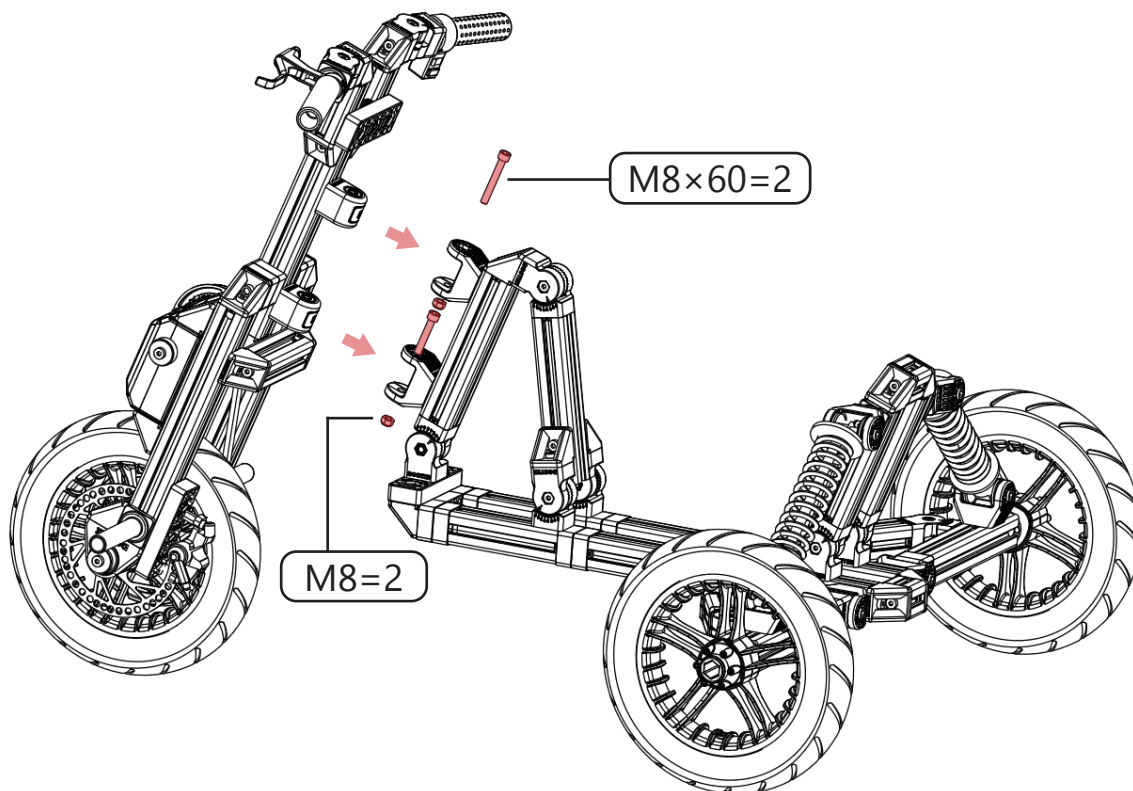

B

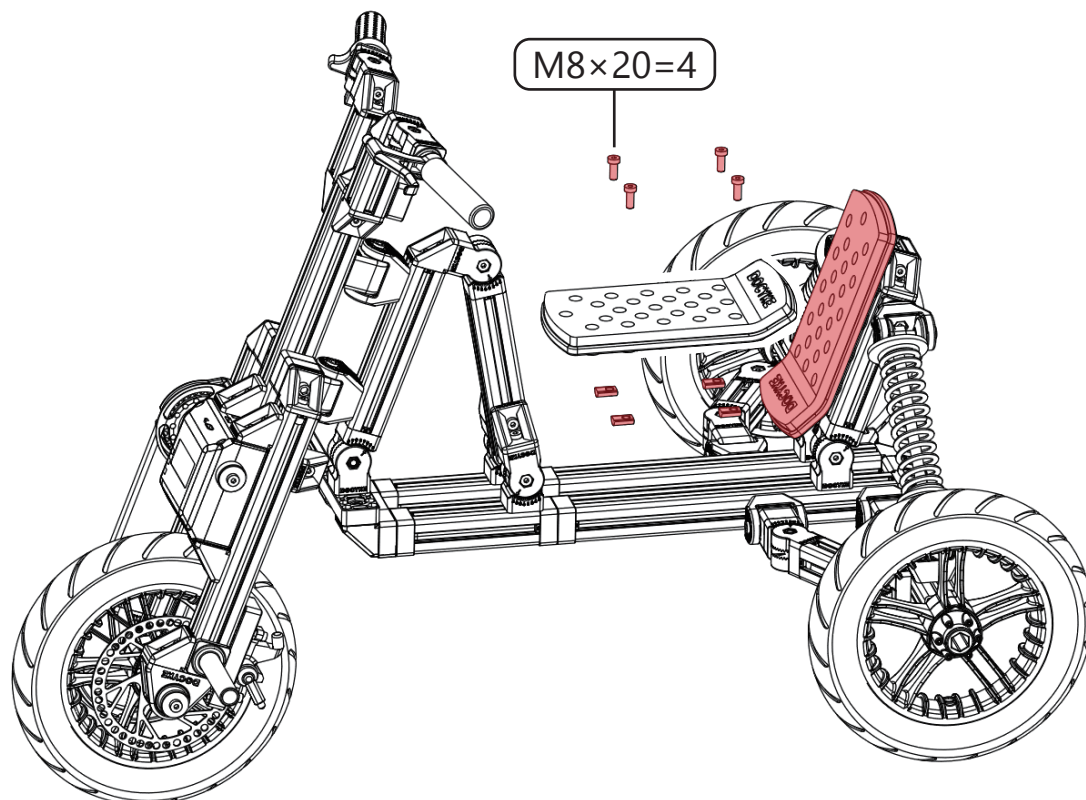

C

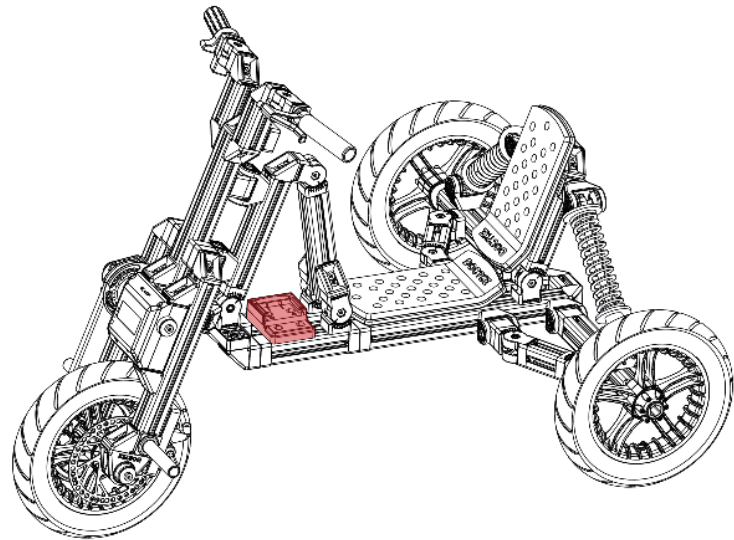
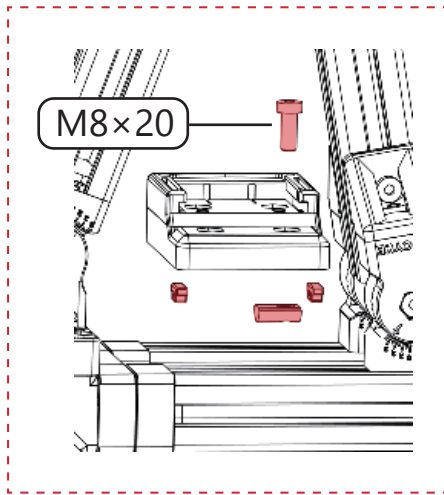

D

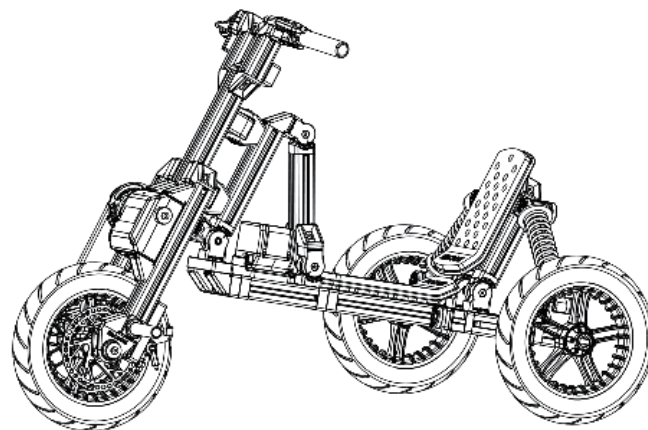
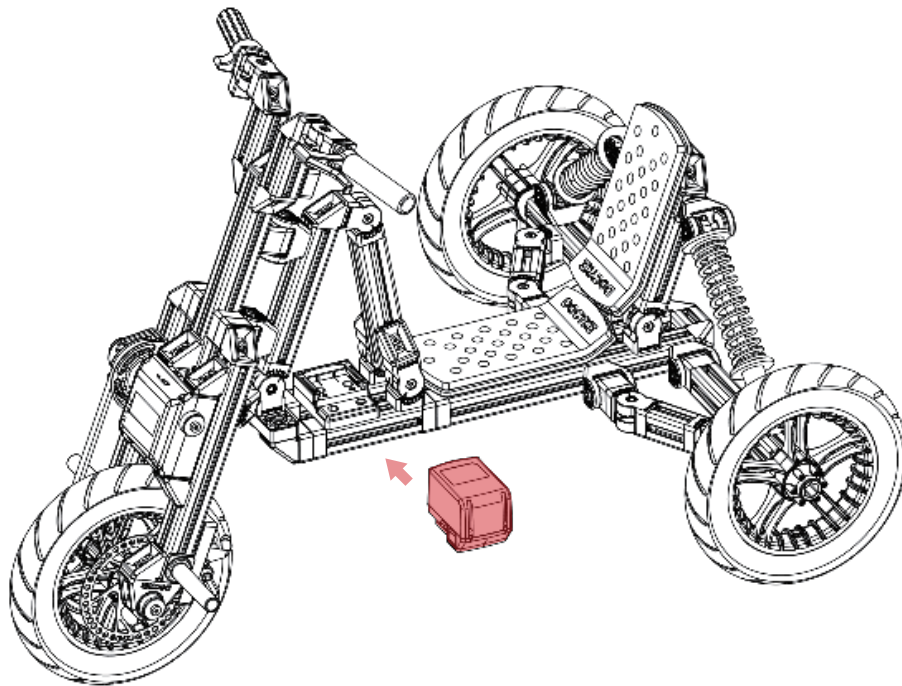

碟刹套件
Brake kit

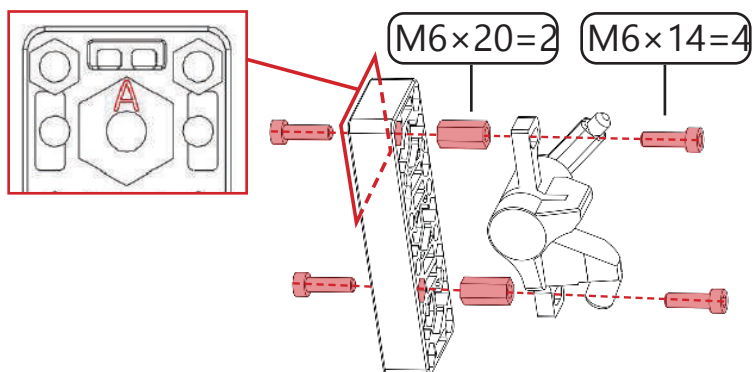
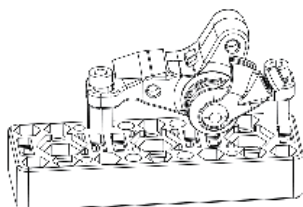
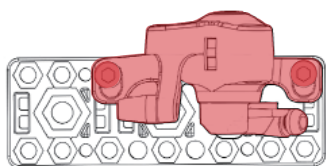

1

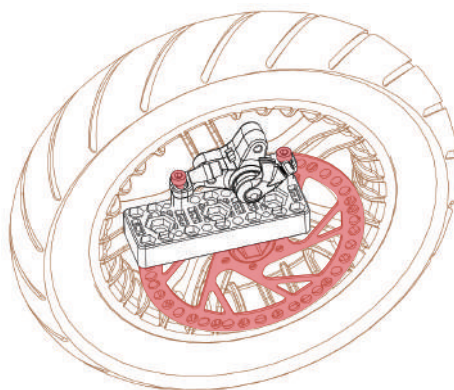
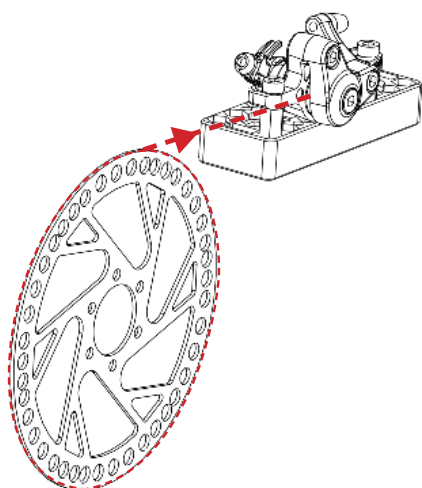

2

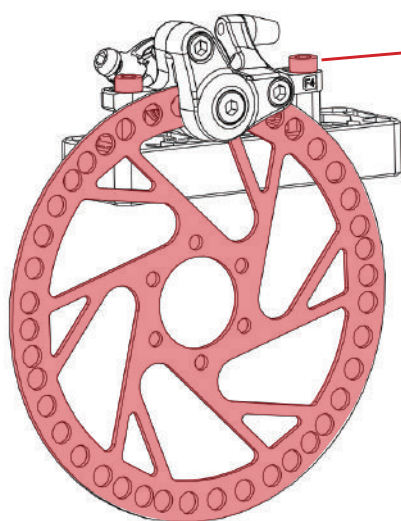

调整刹车片与刹车器之间的间隙，并拧紧螺丝。

Adjust the gap between the brake disc and the brakes then tighten the screws.

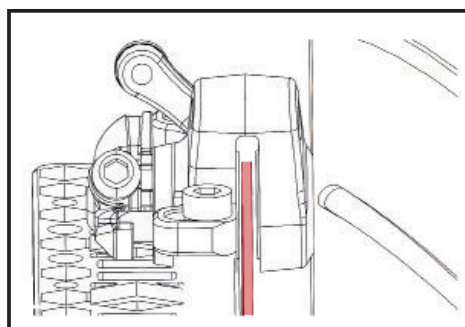

固定线缆。
Fix the cable.

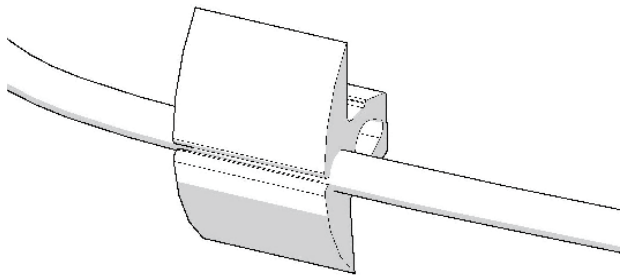
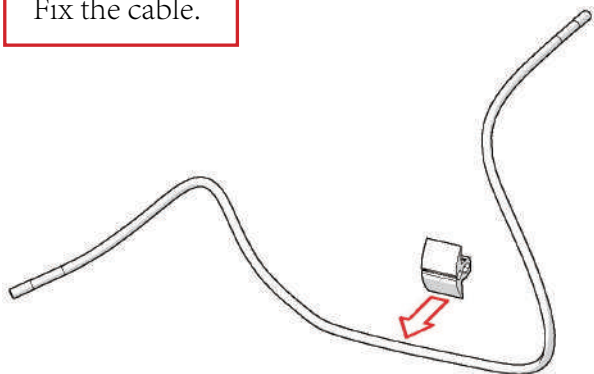

1

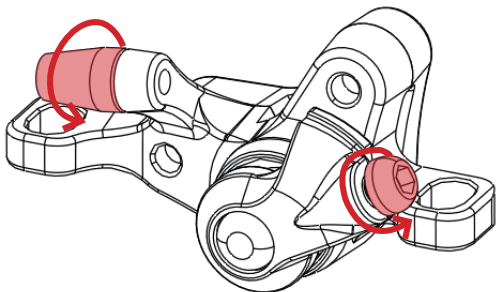

2

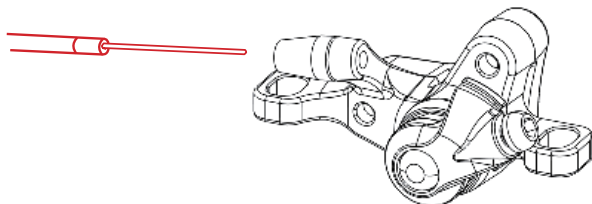

3

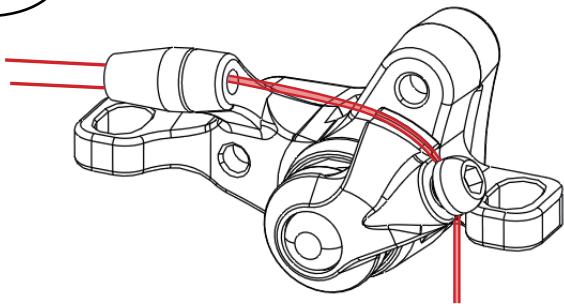

4

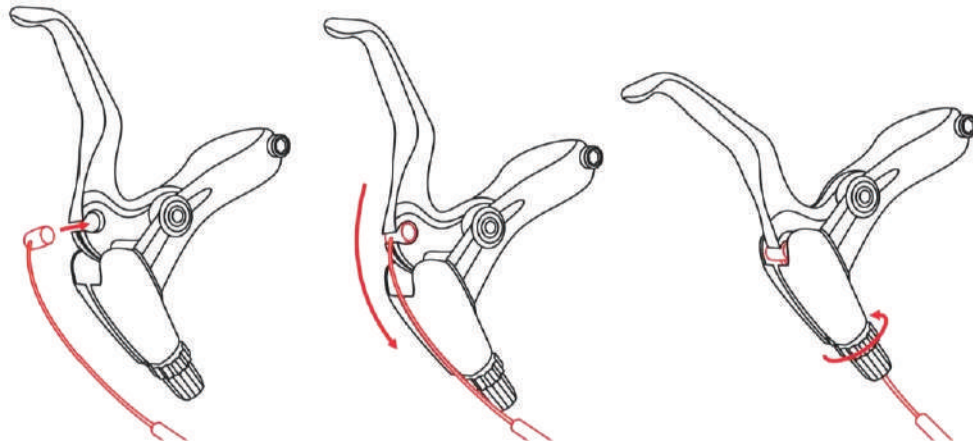
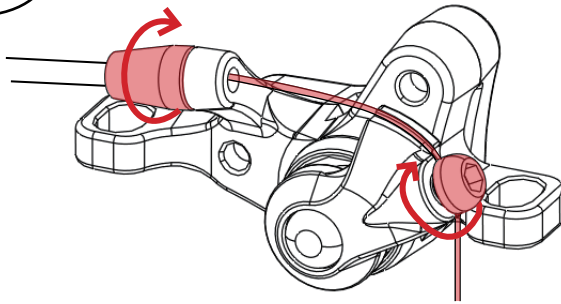

电气连接图

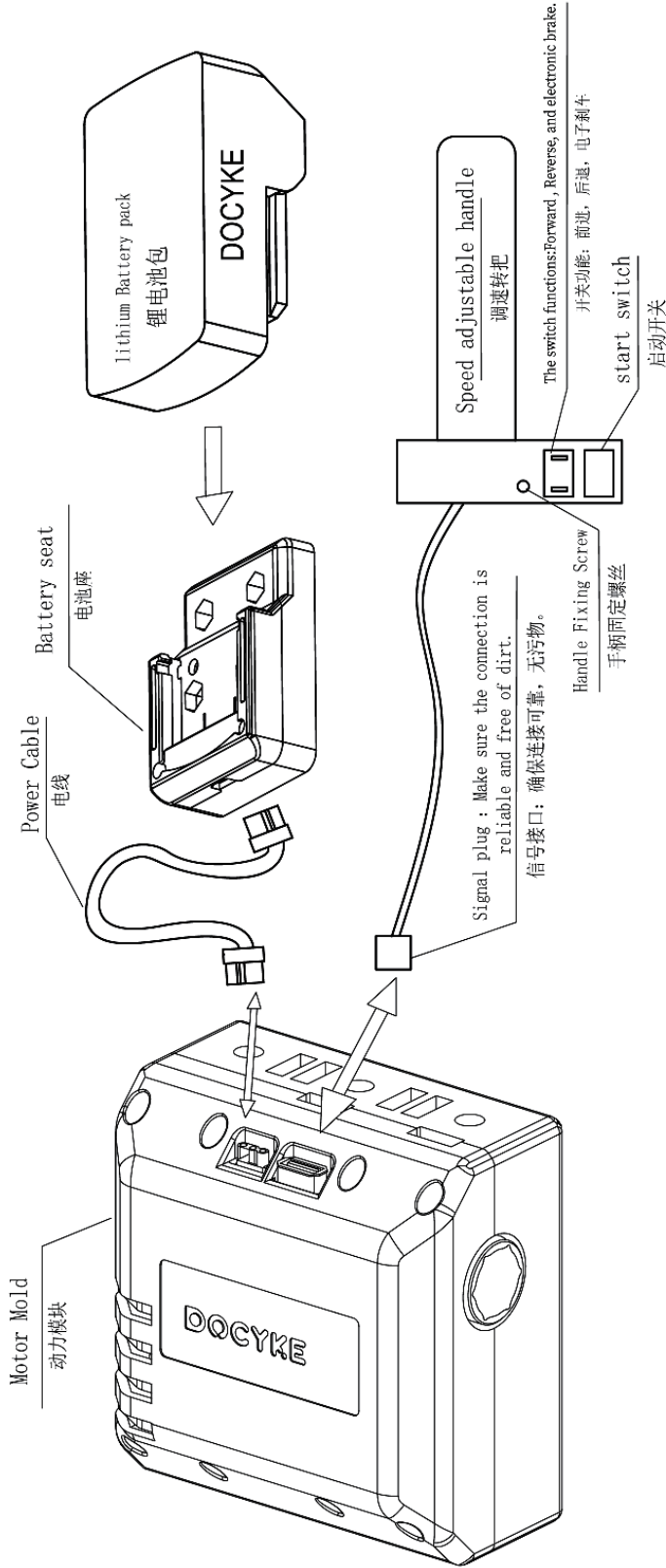

高性能无刷电动模块性能介绍

- 1) 安全防护（碰撞堵转保护、温度保护、过流保护、欠压保护）；
- 2) 电子刹车（前/后开关）；
- 3) 10S不使用，自动进入休眠省电模式；
- 4) 电池：6Ah（使用60分钟）；
- 5) 100-240V/2A自适应充电器（3小时）；

Introduction of High performance brushless motor

1. Safety protection (blocking , overheating , overcurrent , voltage protection)
2. Electronic brake (the F/R switch) .
3. Battery will enter the sleep mode for saving battery in 10 s.
4. Li_battery : 6AH (60 min)
5. Charger :110-240v /2A (3hours) .

GK-02

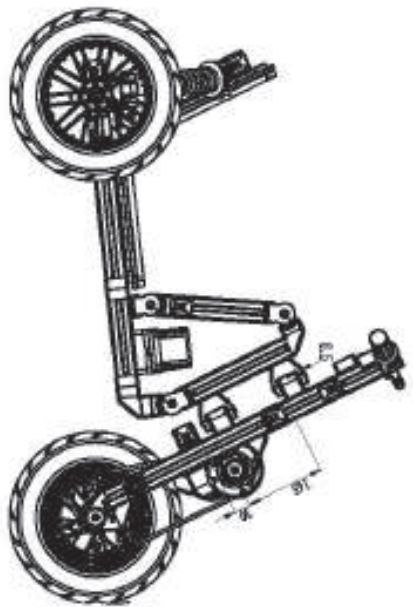
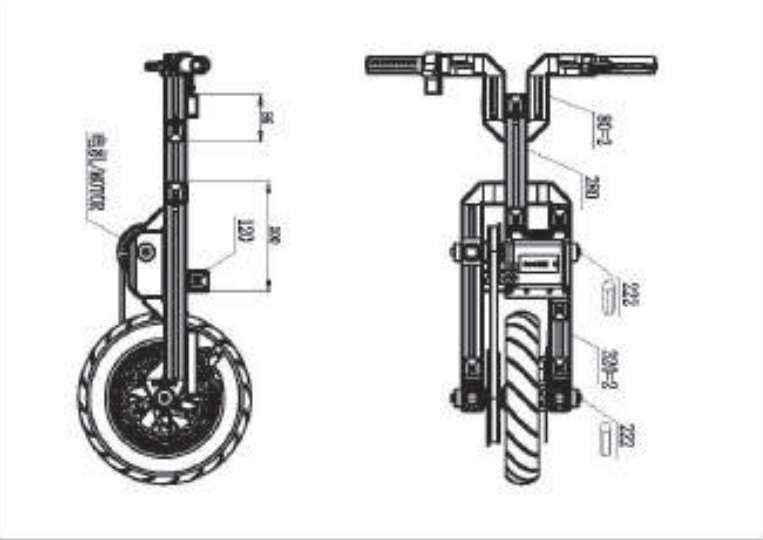
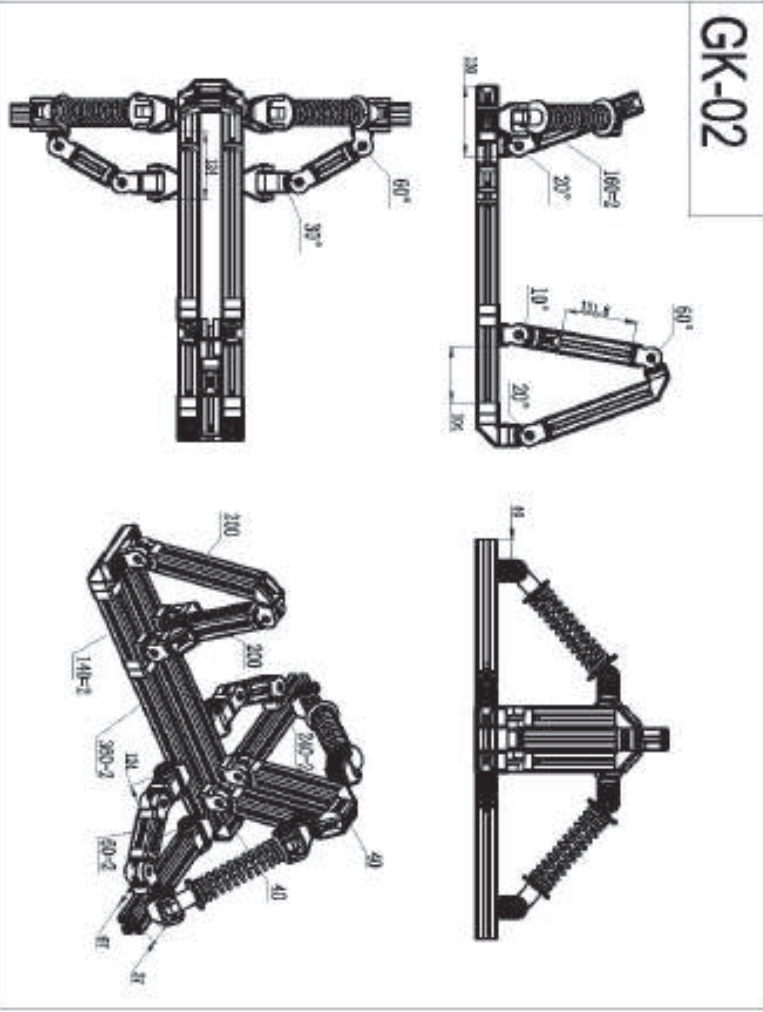

Weight: 28kg/55LB
Load: 50kg/110LB
Speed: 6-11km/h



900mm/35.5IN

1088mm/42.8IN

DOCYKE

www.DOCYKE.com

手机/TEL: 86-180 7222 0126

微信/WECHAT: 86-180 7222 0126

邮箱/E-MAIL: do@docyke.com

地址：中国浙江省绍兴市越城区曹江路二号 科创园 1号楼

ADDRESS: Building 1, Science & Tech Park, No. 2 Caojiang Road,
Yuecheng District, Shaoxing City,China